

E3845 SERIES FRYERS

INSTALLATION, SERVICING and USER INSTRUCTIONS



CAUTION: Read the instructions before using the appliance

IMPORTANT

The installer must ensure that the installation of the appliance is in conformity with these instructions and National Regulations in force at the time of installation. Particular attention **MUST** be paid to:

Gas safety (Installation & Use) regulations

I.E.E. Regulations for Electrical Installations

Health & Safety at work, etc Act

Electricity at Work Regulations

Local and National Building Regulations

Fire precaution Act

This appliance has been UKCA/CE marked based on compliance with the relevant Electrical and Electromagnetic Compatibility (EMC) Regulations/Directives for the voltages stated on the data plate.

WARNING - TO PREVENT SHOCKS, ALL APPLIANCES, GAS OR ELECTRIC, MUST BE EARTHED.

On completion of the installation, these instructions should be left with the Engineer-in-Charge for reference during servicing. Further to this, the user instructions should be handed over to the user, having had a demonstration of the operation and cleaning of the appliance.

IT IS MOST IMPORTANT THAT THESE INSTRUCTIONS BE CONSULTED BEFORE INSTALLING AND COMMISSIONING THIS APPLIANCE. FAILURE TO COMPLY WITH THE SPECIFIED PROCEDURES MAY RESULT IN DAMAGE OR THE NEED FOR A SERVICE CALL.

PREVENTATIVE MAINTENANCE CONTRACT

To obtain maximum performance from this unit regular servicing of the appliance should be undertaken to ensure correct operation, it is functioning as intended, and safe to use. We recommend servicing in accordance with SFG20 Maintenance Schedules and as a minimum, after 2,500 hours of use, or annually, whichever comes first and that a maintenance contract be arranged with an appointed service contact. Visits may then be made at agreed intervals to carry out adjustments and repairs.

We recommend that the oil level sensor **UK Patent Serial No. GB2584184** in the **E3845X/E3845FX/E3845XP/E3845FXP/E3845F2X/E3845F2XP** models should be serviced annually.



WEEE Directive Registration No. WEE/DC0059TT/PRO

At end of unit life, dispose of appliance and any replacement parts in a safe manner, via a licenced waste handler. Units are designed to be dismantled easily and recycling of all material is encouraged whenever practicable.

This equipment is **ONLY FOR PROFESSIONAL USE** and shall be operated by **QUALIFIED** persons. It is the responsibility of the supervisor or equivalent to ensure that users wear **SUITABLE PROTECTIVE CLOTHING** and to draw attention to the fact that some parts will, by necessity, become **VERY HOT** and will cause burns if touched accidentally.

Falcon Foodservice Equipment

HEAD OFFICE AND WORKS

Wallace View, Hillfoots Road, Stirling.

FK9 5PY. Scotland.

Phone: 01786 455200

T101104 Ref 1

CONTENTS

1.0	Safety Guidance	4
1.1	GENERAL SAFETY	4
1.2	INSTALLATION SAFETY	5
1.3	ELECTRICAL SAFETY	5
1.4	GAS SAFETY	5
1.5	FIRE SAFETY	5
1.6	MAINTENANCE SAFETY	6
2.0	INSTALLATION	10
2.1	MODEL NUMBERS, NETT WEIGHTS and DIMENSIONS	10
2.2	SITING	10
2.3	VENTILATION	11
2.4	ELECTRICAL SUPPLY	11
ASSEMBLY and COMMISSIONING		11
2.5	ASSEMBLY	12
2.6	CONNECTION TO AN ELECTRICAL SUPPLY	12
2.7	STARTING UP	12
2.8	PRE-COMMISSIONING CHECK	15
2.9	TEMPERATURE LIMIT THERMOSTAT	16
2.10	OIL LEVEL SENSOR (E3845 'X' variants only)	16
2.11	INSTRUCTION TO INSTALLER	16
SERVICING AND CONVERSION		16
2.12	INTEGRAL COMPONENTS	17
2.13	ACCESS PROCEDURES	18
2.14	ELEMENTS	18
2.15	TEMPERATURE CONTROLLERS	18
2.16	MAINS ON and HEAT DEMAND NEONS (E3845 non-'P' variants only, Figure 8)	18
2.17	DRAIN VALVE	18
2.18	FILTRATION PUMP (E3845 'F' variants only)	18
2.19	TEMPERATURE LIMIT (safety) THERMOSTAT	18
2.20	CONTACTORS & FILTRATION PUMP TIMER	19
2.21	OIL LEVEL SENSOR (E3845 'X' variants only, Figure 8)	19
2.22	TOP UP AND LOW OIL LEVEL LEDS (E3845 'X' variants only, Figure 8)	19
2.23	OIL LEVEL SENSOR EVALUATION UNIT (E3845 'X' variants only, Figure 8)	19
2.24	RELAYS & RELAY BASES (E3845 'X' variants only, Figure 8)	19
SPARES		21
CRITICAL DIMENSIONS		22
OPERATING INSTRUCTIONS		23
2.25	APPLIANCE CONTROLS	24
2.26	OPERATION Safety Precautions	24
2.27	PROGRAMMING THE CONTROLLER - Display Descriptions	26
CHANGING THE OIL		27
2.28	STARTING THE FILTRATION PROCESS	28
CLEANING and MAINTENANCE		29
2.29	CLEANING THE APPLIANCE	29
PREPARATION OF MEDIUM		32
COOKING HINTS		33
WIRING DIAGRAMS		34
2.30	E3845 Front Wiring Diagram	34
2.31	E3845 Rear Wiring Diagram	35
2.32	E3845 Circuit Diagram	36
2.33	E3845X Front Wiring Diagram	37
2.34	E3845X Rear Wiring Diagram	38
2.35	E3845X Circuit Diagram	39
2.36	E3845F Front Wiring Diagram	40
2.37	E3845F Rear Wiring Diagram	41
2.38	E3845F Circuit Diagram	42
2.39	E3845FX Front Wiring Diagram	43

2.40 E3845FX Rear Wiring Diagram44

2.41 E3845FX Circuit Diagram45

2.42 E3845F2 Front Wiring Diagram46

2.43 E3845F2 Rear Wiring Diagram.....47

2.44 E3845F2 Circuit Diagram48

2.45 E3845F2X Front Wiring Diagram.....49

2.46 E3845F2X Rear Wiring Diagram50

2.47 E3845F2X Circuit Diagram51

2.48 E3845P Front Wiring Diagram.....52

2.49 E3845P Rear Wiring Diagram53

2.50 E3845P Circuit Diagram54

2.51 E3845XP Front Wiring Diagram55

2.52 E3845XP Rear Wiring Diagram56

2.53 E3845XP Circuit Diagram.....57

2.54 E3845FP Front Wiring Diagram.....58

2.55 E3845FP Rear Wiring Diagram59

2.56 E3845FP Circuit Diagram60

2.57 E3845FXP Front Wiring Diagram61

2.58 E3845FXP Rear Wiring Diagram62

2.59 E3845FXP Circuit Diagram.....63

2.60 E3845F2P Front Wiring Diagram.....64

2.61 E3845F2P Rear Wiring Diagram65

2.62 E3845F2P Circuit Diagram66

2.63 E3845F2XP Front Wiring Diagram67

2.64 E3845F2XP Rear Wiring Diagram68

2.65 E3845F2XP Circuit Diagram.....69

1.0 SAFETY GUIDANCE

1.1 GENERAL SAFETY



1.1.1 These instructions are only valid if the country code appears on the appliance. If the code does not appear on the appliance, refer to the technical instructions for adapting the appliance to the conditions for use in that country.

1.1.2 These appliances have been UKCA/CE-marked based on compliance with the Gas Appliance Regulations/Product Safety and Metrology Regulations, Electrical and Electromagnetic Compatibility (EMC) Regulations/Directives for the Countries, Gas Types and Pressures as stated on the data plate.



1.1.3 This equipment is for professional use only and must be used by qualified persons.

1.1.4 Never leave this appliance unsupervised when in use and always turn products off at the end of service.



1.1.5 The installer must instruct the responsible person(s) of the correct operation and maintenance of the appliance.

1.1.6 Check that no damage has occurred to the appliance or supply cord during transit. If damage has occurred, do not use this appliance.



1.1.7 If fitted to the appliance, ensure the supply cord is routed free from the appliance to avoid damage.

1.1.8 Min-Level Mark: Medium should never be allowed to drop below the mark. Should this occur, top up immediately or switch off the fryer.



1.1.9 Suitable Protective clothing must be worn when topping up whilst the fryer is hot.

1.1.10 To prevent surge boiling. **DO NOT EXCEED** recommended loads or charge pan with over-wet food items. **NEVER** leave a working appliance unattended.

1.1.11 If the appliance is fitted with an oil bucket, take care when removing as oil bucket is heavy when full.

1.1.12 Training and Competence: To help ensure the safe use of this appliance there is a requirement for you to provide whatever information, instruction, training, and supervision as is necessary to ensure, so far as is reasonably practicable, the health and safety of all users.

1.1.13 For further help and information on training and competence we refer you to the Health & Safety Executive website; www.hse.gov.uk document ref: health and safety training INDG345. International customers should default to the health and safety guidelines provided by your government body.

1.1.14 Risk Assessment: As part of managing the health and safety of your business you must control any risks identified in your commercial kitchen. To do this you need to think about what might cause harm to people and decide whether you are taking reasonable steps to prevent that harm. This is known as risk assessment. It is important to consider the environment around the product as well as the product itself. For example, oil or food spills will present a significant risk so users so the need to immediately clean up such spills must be reflected in staff training.



1.1.15 Record the training that you provide and support it by providing safe system of work (SSOW) documents that set out procedures to be followed for potentially hazardous tasks.

1.1.16 For further help and information on risk assessments we would refer you to you the Health and Safety Executive website; www.hse.gov.uk document ref: risk assessment INDG163. International customers should default to the health and safety guidelines provided by your government body.

1.2 INSTALLATION SAFETY



- 1.2.1 Installation must meet national or local regulations. Attention must be paid to: safety (installation & use) regulations, health and safety at work act, local and national building regulations, fire precautions act.
- 1.2.2 The installer must instruct the responsible person(s) of the correct operation and maintenance of the appliance.
- 1.2.3 On gas appliances, only competent persons are allowed to service or convert the appliance to another gas type.
- 1.2.4 Put a documented system in place for periodic inspections, testing and maintenance of our gas/ electrical appliances. Check that the fixed electrical installation has been inspected and tested by a competent electrical contractor (e.g. NICEIC-approved or ECA member) as prescribed in BS7671, within the last 5 years.

1.3 ELECTRICAL SAFETY



- 1.3.1 To prevent shocks, this appliance must be earthed.
- 1.3.2 This unit is fitted with an equipotential connection at the rear on the base.
- 1.3.3 Before attempting any maintenance, isolate the appliance at the mains switch and take steps to ensure that it is not inadvertently switched on.
- 1.3.4 We recommend, Supplementary electrical protection with the use of a type A residual current device (RCD).
- 1.3.5 Fixed wiring appliances incorporate a locally situated switch disconnector.
- 1.3.6 to connect to, which is easily accessible for switching off and safe isolation purposes. The switch disconnector must meet the specification requirements of IEC 60947.

1.4 GAS SAFETY



- 1.4.1 Gas appliances must have a stop cock fitted in the supply pipe work. The user must be familiar with the location and operation of this device in order to turn off the supply of gas in the event of an emergency.
- 1.4.2 Before Inspection, Servicing or Conversion, Turn Off Gas at isolator.

1.5 FIRE SAFETY



Fryers can present various hazards in the catering environment if not correctly used, operated, and maintained. Hazards including fire, burns from hot oil, contact with hot surfaces, fumes from boiling cleaning chemicals, eye injuries from splashes and slips from oil spillages.

Operator Competency and Training

Ensure you are trained in the safe and proper use of the fryer and know how to turn it off and switch the power or gas off at the mains.

- 1.5.1 **Ensure you are familiar with the kitchen fire safety procedures and the location and proper use of correct fire safety equipment.**

Fryer Safety Equipment

- 1.5.2 **Provide an appropriate BS compliant fire blanket, and an adequate number of fire extinguishers that comply with BS EN 3 (parts 1-6) and carry a BAFF or LPCB approval mark. At least one must be appropriate for use on electrical fires, and one for deep-fat fryers (Class F).**

Fryer Suppression System

- 1.5.3 We recommend kitchen equipment and extraction systems are protected with a fire suppression system. Check your insurance as this may also be a condition of your policy.
- 1.5.4 Protect cooking and extraction equipment (including any associated extraction ductwork and hoods inside the building) by having an extinguishing system installed, in line with (or the equivalent of) [LPS 1223](#). The system should include a local alarm, automatic activation by a detection system and manual activation – located a safe distance away from the cooking equipment, preferably by a fire escape route door.

Operational Fryer Safety

- 1.5.5 Do not leave the fryer unattended when powered on or when it is in use.
- 1.5.6 Always switch the fryer off and replace the pan cover/ lid when not in use.

Cleaning

- 1.5.7 Ensure fryers are regularly cleaned serviced and maintained by a qualified and competent service provider, and there is enough room around the appliance to do so.
- 1.5.8 Ensure that the appliance, surrounding work area and extraction system are regularly cleaned, (at least weekly) to avoid the build-up of fats oils and greases that could present a fire risk. A deep clean should be undertaken at least every 6 months by a specialist contractor.

Oil Safety

- 1.5.9 Do not operate the fryer with no or low oil levels.
- 1.5.10 Solid Fat (e.g. Beef Tallow) must be melted using the fat melt mode in order to avoid fire caused by burning of the fat and/or overheating. We do not recommend using Solid Fat if the fryer control does not have a Fat Melt Cycle.
- 1.5.11 Regularly change your cooking oil. Use colour charts to check on oil quality.
- 1.5.12 If you see the cooking oil or fat smoking, switch the fryer off, allow to cool, drain oil, clean and dry fryer pan thoroughly and replace with fresh oil. If the clean fryer oil smokes when heated, switch off immediately and contact service engineer. Do not switch fryer back on.
- 1.5.13 Never add water to the fryer medium at any time.



Gas and Electrical Isolation Points

- 1.5.14 Ensure any separate gas shut off switches and electric switches provided for cooking equipment and/or extractor fans are accessible and clearly labelled.

Care and Maintenance of Thermal and Operational Safety Devices

- 1.5.15 Your fryer is fitted with a thermal safety device. This will stop heating of medium if it becomes overheated. This appliance will always fail safe so long as there is no damage to the thermal safety device.
- 1.5.16 Failure to clean and check the safety and operational thermostats can impact the performance of the appliance and increase the risk of an appliance fire.
- 1.5.17 Damage to the thermostat sensors or their capillaries can increase the risk of overheating or fire.
- 1.5.18 Do not operate the fryer if the safety devices located within the fryer pan appear to be dislodged or damaged.



1.6 MAINTENANCE SAFETY



- 1.6.1 Unless otherwise stated, parts which have been protected by the manufacturer must not be adjusted by the installer or end user.
- 1.6.2 We recommend that the oil level sensor (UK Patent Serial No. GB2584184) in X or FX models should be serviced annually.



1.6.3 Before any cleaning is undertaken, isolate appliance from mains power supply at isolator switch.



1.6.4 Suitable protective clothing must be worn when cleaning this appliance.

1.6.5 If filtration is fitted, never pump water through the filtration pump at any time! Water and hot oil are an explosive mixture.

1.6.6 Oil must be allowed to cool to a safe temperature before draining. Do not overfill the oil bucket. All spills onto the product and on the floor should be cleaned up immediately

1.6.7 The appliance must not be cleaned with a jet of water or steam cleaned. Do not use acid or halogen-based (e.g., chlorine) descaling liquids, flammable liquids, cleaning aids or cleaning powders.

1.6.8 Failure due to lack of proper cleaning is not covered by warranty.

1.6.9 Particular attention must be paid to cleaning the Thermostat bulb & Capillaries.

1.6.10 Take care when cleaning not to dislodge or damage thermostat sensors mounted on the base and side of the pan.



1.6.11 If the thermostats or capillaries are damaged, then do not turn the appliance on and contact Falcon or you approved service provider to undertake the necessary repairs.



1.6.12 In the extraordinary event that the oil level sensor does come into contact with fire the probe should be replaced.



1.6.13 To obtain maximum performance from this unit regular servicing of the appliance should be undertaken to ensure correct operation, it is functioning as intended, and safe to use. We recommend servicing in accordance with SFG20 Maintenance Schedules and as a minimum, after 2,500 hours of use, or annually, whichever comes first and that a maintenance contract be arranged with an appointed service contact. Visits may then be made at agreed intervals to carry out adjustments and repairs.



1.6.14 During Servicing of the appliance, where applicable, please ensure seals are checked. If the integrity of the seal is compromised, it must be replaced

IMPORTANT INFORMATION

ELECTRICAL SAFETY AND ADVICE REGARDING SUPPLEMENTARY ELECTRICAL PROTECTION

Commercial kitchens and foodservice areas are environments where electrical appliances may be located close to liquids or operate in and around damp conditions or where restricted movement for installation and service is evident.

The installation and periodic inspection of the appliance should only be undertaken by a qualified, skilled and competent electrician; and connected to the correct power supply suitable for the load as stipulated by the appliance data label.

The electrical installation and connections should meet the necessary requirements to the local electrical wiring regulations and any electrical safety guidelines.

We recommend:

- Supplementary electrical protection with the use of a type A residual current device (RCD)
- Fixed wiring appliances incorporate a locally situated switch disconnecter to connect to, which is easily accessible for switching off and safe isolation purposes. The switch disconnecter must meet the specification requirements of IEC 60947.

Your attention is drawn to:

BS 7671:2018–Guidance Note 8 - 8.13: Other locations of increased risk.

It is recognized that there may be locations of increased risk of electric shock other than those specifically addressed in Part 7 of BS 7671. Examples of such locations could include laundries where there are washing and drying machines in close proximity and water is present, and commercial kitchens with stainless steel units, where once again, water is present.

Where because of the perception of additional risks being likely, the installation designer decides that an installation or location warrants further protective measures, the options available include:

- Automatic Disconnection of Supply (ADS) by means of a residual current device having a residual operating current not exceeding 30mA;
- Supplementary protective equipotential bonding; and
- Reduction of maximum fault clearance time.

The provision of RCDs and supplementary bonding must be specified by the host organization's appointed installation designer or electrical contractor and installed by a suitably qualified and competent electrician so as to comply with Regulations 419.2 and 544.2.

Training and competence

To help ensure the safe use of this appliance there is a requirement for you to provide whatever information, instruction, training, and supervision as is necessary to ensure, so far as is reasonably practicable, the health and safety of all users.

For further help and information on training and competence we would refer you the Health and Safety Executive website; www.hse.gov.uk document ref: health and safety training INDG345. International customers should default to the health and safety guidelines provided by your government body.

Risk assessment

As part of managing the health and safety of your business you must control any risks identified in your commercial kitchen. To do this you need to think about what might cause harm to people and decide whether you are taking reasonable steps to prevent that harm. This is known as risk assessment. It is important to consider the environment around the product as well as the product itself. For example oil or food spills will present a significant risk so users so the need to immediately clean up such spills must be reflected in staff training.

For further help and information on risk assessments we would refer you to you the Health and Safety Executive website; www.hse.gov.uk document ref: risk assessment INDG163. International customers should default to the health and safety guidelines provided by your government body.

Cleaning and maintenance

When removing heavy items to aid cleaning or maintenance particular care should be taken. A manual handling risk assessment is the best way to determine the level of risk to anyone using or maintaining this equipment. To help with such an evaluation we have included the weights of individual components that may present significant risk.

For further help and information on manual handling and associated risk assessment we would refer you to you the Health and Safety Executive website; www.hse.gov.uk document ref: manual handling at work INDG143. International customers should default to the health and safety guidelines provided by your government body.

The cleaning of fryers or other products that use hot oil present significant risks to end users and particular care should be taken. Cold water and hot oil for example are an explosive mix and should be avoided at all costs.

Other useful references for health and safety issues www.hse.gov.uk
Essentials of health and safety at work ISBN978
Noise at work INDG362
Safe systems of work
Other notes added to the body of the instructions.

2.0 INSTALLATION



UNLESS OTHERWISE STATED, PARTS WHICH HAVE BEEN PROTECTED BY THE MANUFACTURER ARE NOT TO BE ADJUSTED BY THE INSTALLER.

Please ensure that any plastic coatings are removed prior to use. Before operation, the pan requires to be thoroughly cleaned and dried.

Discolouration of heated parts is caused by factory testing to ensure a satisfactory unit. It does not affect quality or performance.

2.1 MODEL NUMBERS, NETT WEIGHTS and DIMENSIONS

Model	Width (mm)	Depth (mm)	Height (mm)	Weight (kg)
E3845 / E3845P	400	800	880	72
E3845X / E3845XP	400	800	880	76
E3845F / E3845FP	400	800	880	83
E3845FX/ E3845FXP	400	800	880	87
E3845F2/E3845F2P	400	800	880	86
E3845F2X/E3845F2XP	400	800	880	90

Pan oil capacity: 10 litres cold, good quality oil (to –MIN- mark) per pan.

2.2 SITING

The unit must be installed on a firm level floor in a well-lit draught free position. The fryer should not be installed in a position where the possibility of sideways tipping is likely when force is applied. The means of restraint may be the manner of installation, such as connection to a battery of appliances or installing the fryer in an alcove, or by separate means, such as adequate ties.

2.2.1 Anti-tipping Bracket

An anti-tipping mechanism is available as an accessory. If fitted, the brackets must be installed to locate the fryer in the correct position relative to any walls as detailed below. Fixing holes are provided in fryer base to accommodate the bracket. Details of fitting can be found in Figure 1 below.

Attach securely to fixing point and secure bracket to floor after alignment with bracket attached to the fryer. Adjust bracket to slide below floor bracket.

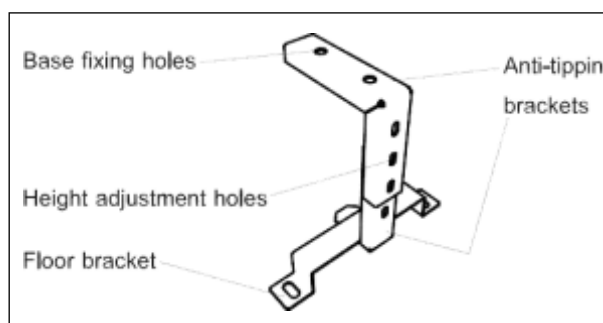

Figure 1 - Anti-tipping Bracket

2.2.2 Clearances

The unit requires a clearance of at least 100mm to the rear between unit and any combustible wall. A minimum vertical clearance of 750mm should be allowed between top edge of flue outlet and any overlying combustible surface.



Important

If fryer is to be installed with other appliances, then the instructions for every model should be consulted to determine the necessary clearance to any wall or overlying surface.

Some appliances require greater clearance distances than others. The largest clearance will therefore determine overall distance for a complete suite of adjoining appliances.

2.3 VENTILATION

The appliance ventilation requirements should be in line with national and local regulations. For multiple installations, requirements should be added together. Installations should be made in accordance with local and/or national regulations applying at the time. A competent engineer must be used for any installation work.

2.4 ELECTRICAL SUPPLY

The unit is supplied with a 2 metre 5-core cord for connection to a 400V 3N~ supply incorporating a suitable isolating switch.

In the event of the cable being replaced, a cable conforming to code designation 0245 IEC 57 (e.g., H07RH-F5G4) must be used for connection to a 400V 3N~ supply incorporating a suitable isolating switch.

Check that no damage has occurred to the appliance and power cable during transit. If damage has occurred do not use the appliance.

Ensure that the mains power cable is routed free from the appliance to avoid damage.

We recommend supplementary electrical protection with the use of a type A residual current device (RCD). Periodical testing, repair and fixing wiring connection should only be undertaken by a skilled and competent electrician.



This appliance is also provided with a terminal for connection of an external equipotential conductor. This terminal is in effective electrical contact with all fixed exposed metal parts of the appliance and shall allow the connection of a conductor having a normal cross-sectional area of up to 10mm². It is located on the rear panel and is identified by the following symbol and must only be used for bonding purposes.

Phase	Rated Current
L1	29A
L2	29A
L3	29A

3.0 ASSEMBLY and COMMISSIONING

The electrical cable must be connected in accordance with the various regulations listed on the cover of this manual.

3.1 ASSEMBLY

1. **Unpack appliance.**
2. **Unpack fryer baskets and accessories.**
3. **Place element guard and baskets in pan.**
4. **Level appliance and fit all service protection kits.**
5. **(Anti-tilt kit, if ordered as accessory).**

3.2 CONNECTION TO AN ELECTRICAL SUPPLY

The supply cable must be connected to a suitable isolator switch as follows:

Phase 1	Phase 2	Phase 3	Neutral	Earth
Brown	Black	Grey	Blue	Green/Yellow

3.3 STARTING UP

3.3.1 E3845/E3845F/E3845F2 Fryer Control Panel (See Figure 2)

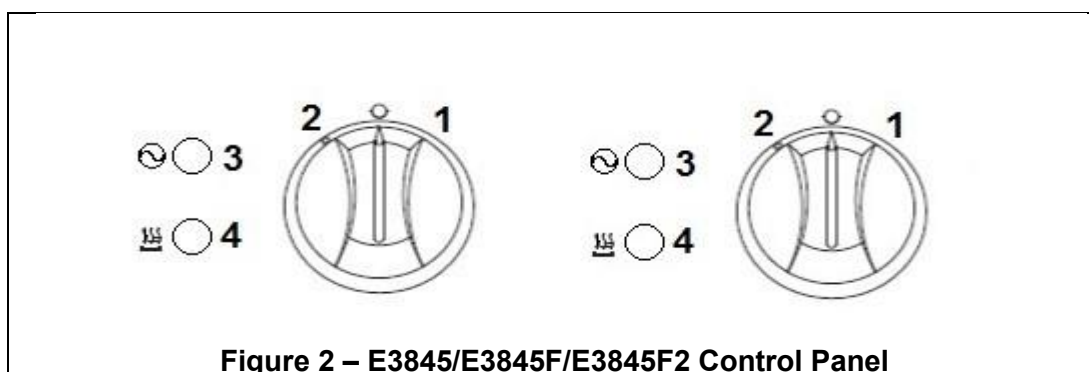

1. **ON/OFF and Temperature Control Knob:** Temperature Selection (140 - 190°C). Unit is off when in position indicated.
2. **Fat Melt Position:** Feature for slow pulsed heating of solid fats.
3. **Power on indicator (Red)**
4. **Heat Demand Indicator (Amber):** Illuminates when elements are on. Goes out when desired temperature is reached.

3.3.2 E3845X/E3845FX/E3845F2X Fryer Control Panel (See Figure 3)

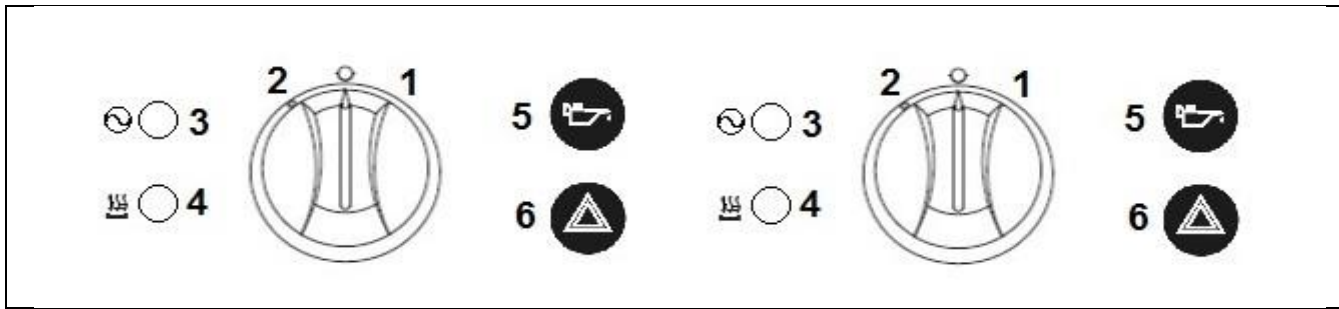

Figure 3 – E3845X/E3845FX/E3845F2X Control panel

1. **ON/OFF and Temperature Control Knob:** Temperature Selection (130 - 190°C). Unit is off when control is in position indicated.
2. **Fat Melt Position:** Feature for slow pulsed heating of solid fats.
 - **E3845X, E3845FX & E3845F2X Only:** For first use it is recommended that the solid fat is pre-melted before being added to the fry pot.
3. **Power On Indicator (Red):** Illuminates when the appliance is switched on.
4. **Heat Demand Indicator (Amber):** Illuminates when thermostat demands heat, i.e. oil temperature is more than 5°C below temperature setting. Extinguishes when desired temperature is reached.
5. **Top Up Oil Indicator (Orange, Oil Can Symbol):** Indicates when the oil level has dropped at least 40mm below the MIN mark.
6. **Low Oil Level Indicator (Red Flashing, Hazard Triangle):** Indicates when the oil has dropped to the same level as the temperature probe approximately 80mm below MIN mark.

3.3.3 E3845P/E3845FP/E3845F2P Fryer Control Panel (See Figure 4)

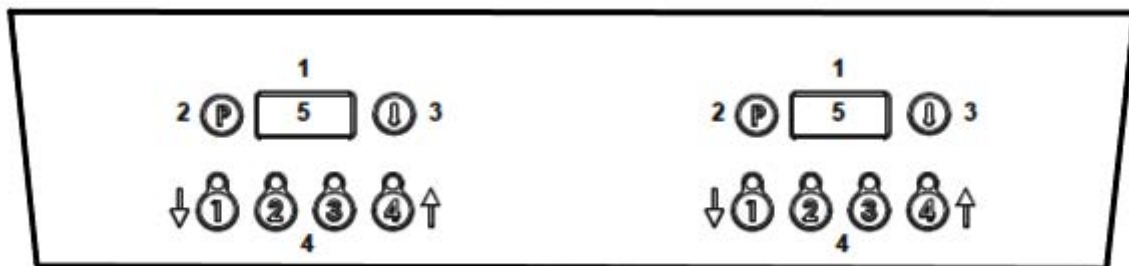

Figure 4 – E3845P/E3845FP/E3845F2P Control Panel

1. **Four Digit LED Display:** Displays Set temp, Actual temp, cook time remaining and used for programming purposes.
2. **Program Button:** Used to enter timer programme mode to change each of the 4 pre-set timers select channels (see section 6).
3. **Temperature Button:** Used to view actual/set temperature and to enter set temperature mode (see section 6).
4. **Timer Keys (1 – 4):** Used to start/cancel pre-set cook times. Buttons 1 & 4 also used to change times or temperatures when in either set mode (see section 6).
5. **Heat Demand LED Indicator (not shown):** Illuminates when thermostat demands heat, i.e., oil temperature is more than 2°C below programmed set temperature. Will extinguish when desired setting

is reached.

3.3.4 E3845XP/E3845FXP/E3845F2XP Fryer Control Panel (See Figure 5)

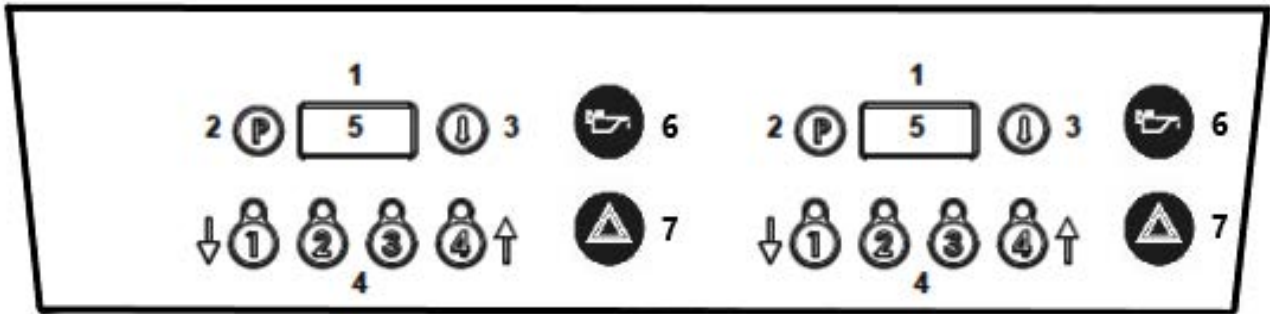
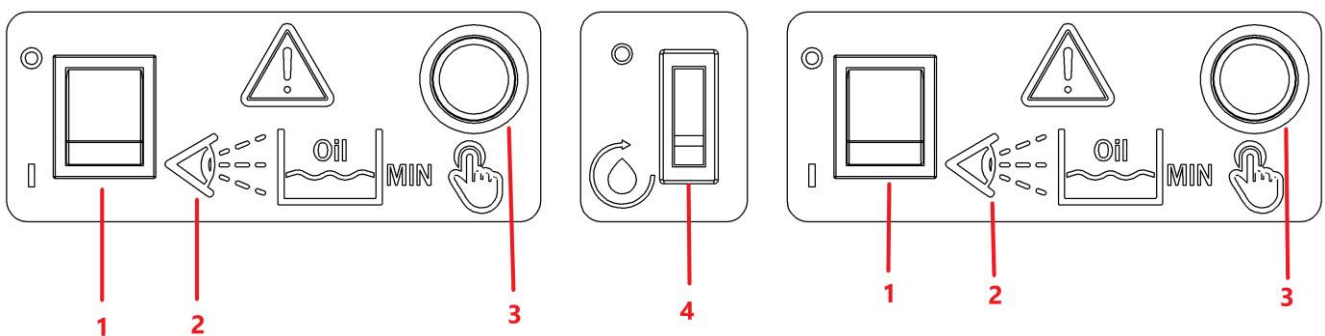

Figure 5 – E3845XP/E3845FXP/E3845F2XP Control panel

1. **Four Digit LED Display:** Displays set temp, actual temp, cook time remaining and used for programming purposes.
2. **Program Button:** Used to enter timer programme mode to change each of the 4 pre-set timers select channels (see section 6).
3. **Temperature Button:** Used to view actual/set temperature and to enter set temperature mode (see Section 6).
4. **Timer Keys (1 – 4):** Used to start/cancel pre-set cook times. Buttons 1 & 4 also used to change times or temperatures when in either set mode (see section 6).
5. **Heat Demand LED Indicator (not shown):** Illuminates when thermostat demands heat, i.e., oil temperature is more than 2°C below programmed set temperature. Will extinguish when desired setting is reached.
6. **Top Up Oil Indicator (Orange, Oil Can Symbol):** Indicates when the oil level has dropped at least 40mm below the MIN mark.
7. **Low Oil Level Indicator (Red Flashing, Hazard Triangle):** Indicates when the oil has dropped to the same level as the temperature probe approximately 80mm below MIN mark.

3.3.5 E3845F/E3845F2/E3845FP/E3845F2P - Additional Controls (See Figure 6).



E3845F - Figure 6 - Additional Controls

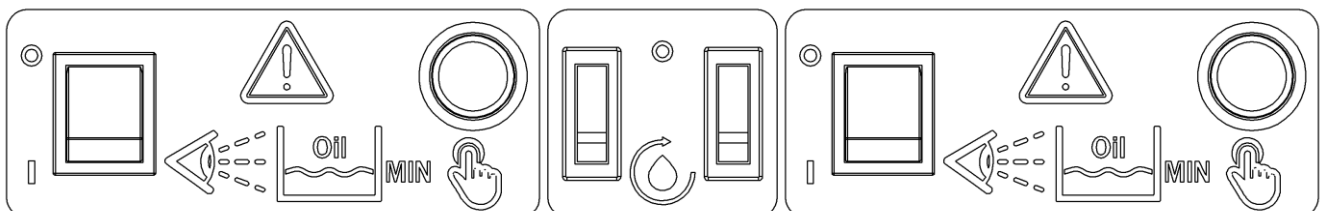

E3845F2

The following additional controls are located behind cabinet door.

1. **Pan ON/OFF Switches:** Both pans are controlled by individual on/off switches that cut power to appliance.
2. **Check Oil Level Lamp / Buzzer:** Both pans have a 'check oil level' indicator to prompt operator to check there is oil / sufficient oil in the pan(s).
3. **Start Button:** Both pans have a start button. Once operator has established there is sufficient oil in the pan, pushing will engage the controller (See figure 4).
4. **Filtration Switch:** Used to operate filtration pump when filtering is required (E3845F2, E3845F2X, E3845F2P & E3845F2XP has an individual switch for each pan).

3.3.6 Temperature Safety Limit Device Reset Button (2 Off)

Located on rear of element box, below black dust cap, refer to Figure 7.

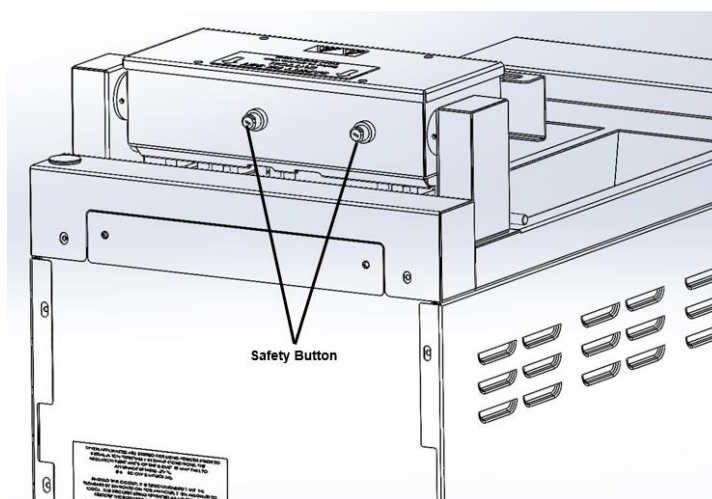

Figure 7 – Reset Button

3.3.7 E3845/E3845F/E3845F2/E3845X/E3845FX/E3845F2X Fryers Controller Diagnostic Indicators (Refer to Wiring Diagrams)

On PCB Controller

- CR2, Green LED 'ON' indicates heat demand.
- CR2, Green LED 'OFF' indicates no heat demand.
- CR9, Red LED flashes if temperature probe is either short or open circuited.
- CR9, Red LED is permanently 'ON' to indicate system is OK. Set point is +/-7°C of mid-set point.

3.4 PRE-COMMISSIONING CHECK

3.4.1 Clean out pan thoroughly using hot water and detergent. Rinse out and dry thoroughly.

Note: For further detail with regard to cleaning, refer to Section 9.

3.4.2 Checking Controller Operation

To check operation of controls, refer to Using the Controller - Section 7.2.4.

3.4.3 Checking Oil Filtration Pump E3845F/E3845F2/E3845FX/E421F2X/E3845FXP/E3845F2XP only.

To check operation of oil filtration pump, refer to Section 8.

3.5 TEMPERATURE LIMIT THERMOSTAT

The unit is equipped with an additional temperature limit thermostat, independent of the main controller. In the case of operating thermostat failure, allowing oil temperature to rise above predetermined legislation safe zone (230°C), limit device will activate and cut power to controller and elements.

To re-set temperature limit thermostat (refer to Figure 7):

1. **Switch fryer ON/OFF switch to OFF position.**
2. **Allow oil to cool below 150°C**
3. **To reset limit thermostat, unscrew black dust cap located at element box rear. Press reset button and replace cap.**
4. **Turn fryer ON/OFF switch to ON position and press start button.**
5. **Reselect temperature.**
6. **If limit thermostat reactivates carry out fault finding on temperature control circuitry.**

3.6 OIL LEVEL SENSOR (E3845 'X' variants only)

The unit is equipped with an additional Oil Level Sensor **UK Patent Serial No. GB2584184.**

When the oil level drops to at least 15mm below the MIN mark, then the Top Up Oil LED will indicate (Orange oil can symbol) warning the user that the oil level has dropped considerably.

When the oil level drops below at least 45mm below the MIN mark, the Low Oil Level LED will indicate (Flashing red hazard triangle) warning the user that the oil level is unacceptable.

At this point the fryer will stop the elements from energising. The fryer cannot be started until the fry pot has been filled with oil to an acceptable level.

3.7 INSTRUCTION TO INSTALLER

After installing and commissioning appliance, please hand Instructions to user or purchaser and ensure that the person(s) responsible understands the instructions and how to correctly operate and clean the unit in a safe manner.

Emphasis should be given to safe operation and use of drain valve and oil bucket. Oil bucket should not be overfilled to allow safe movement. Oil should be allowed to cool before any manual handling.

4.0 SERVICING AND CONVERSION

SERVICE INFORMATION

This unit carries an extensive mainland UK warranty. The warranty is in addition to and does not change your statutory or legal rights.

The warranty policy can be found on our website which details the conditions of the warranty and the exclusions.

<https://www.falconfoodservice.com/info-centre/policy>



Service calls to equipment under warranty will be carried out in accordance with the conditions of sale.

Warranty calls can be made between 8:30 am and 5:00 pm weekdays only.

To ensure your warranty enquiry is handled as efficiently as possible, ensure you have the following appliance information prior to calling us:

1. **Model number:** found on data plate.
2. **Serial number:** found on data plate.
3. **Brief description of the issue.**

To contact Falcon for a warranty issue dial (UK only) 01786 455 200 and select Warranty Issues from the menu.



BEFORE ATTEMPTING ANY SERVICING, TURN OFF GAS SHUTOFF VALVE AND ELECTRICAL SUPPLY. TAKE STEPS TO ENSURE THAT THESE CANNOT BE INADVERTENTLY TURNED ON.

AFTER ANY MAINTENANCE TASK, CHECK UNIT TO ENSURE THAT IT PERFORMS SAFELY AND CORRECTLY AS DESCRIBED IN SECTION 2.4.



MAINTENANCE CHECK

Regular servicing of the appliance should be undertaken to ensure correct operation, it is functioning as intended, and safe to use. We recommend servicing after 2,500 hours of use, or annually, whichever comes first. Any maintenance schedule should be carried out in accordance with SFG20 Maintenance Schedule. Should any issues with the integrity of the components be identified these should be replaced. If the appliance is not considered safe the unit should be removed from service and the responsible person advised why the unit is not safe to use and what remedial action is needed. Contents of the maintenance schedule should be agreed with the maintenance provider.

4.1 INTEGRAL COMPONENTS

The following parts must be checked and serviced regularly:

1. Oil ingress to electrical components.
2. Visual inspection of components and fryer pan.
3. Temperature limit thermostat calibration.

4.2 ACCESS PROCEDURES

Before removal of any fryer components:

1. Ensure appliance electrical supply has been shut off and cannot be accidentally turned back on.
2. Allow oil to cool before any operation that requires pan to be drained.
3. Only use parts specified by the manufacturer.
4. All components replaced **MUST** be fully checked after fitting to ensure safe operation.
5. A full pre-commissioning check as detailed in Section 3.4 should be carried out.

4.3 ELEMENTS

1. Remove fixings from element box lid and release element cables.
2. Tilt element box and rest in upright position.
3. Remove four fixings from element mounting plate.
4. Remove element and seal.
5. Replace in reverse order.

4.4 TEMPERATURE CONTROLLERS

1. Remove control panel by undoing fixings at top and bottom.
2. Disconnect electrics and remove fixings to enable controller to be removed.
3. Carefully replace in reverse order.

4.5 MAINS ON and HEAT DEMAND NEONS (E3845 non-‘P’ variants only, Figure 8)

1. Remove control panel by undoing fixings at top and bottom of control panel.
2. Remove electrical connections from neon. Undo neon retention nut.
3. Carefully replace in reverse order.

4.6 DRAIN VALVE

1. Ensure fry pot is empty. Refer to Section 8.
2. Remove nut from handle and lift handle off.
3. Remove front panel fasteners.
4. Disconnect wiring, noting all connections.
5. Remove front panel to access drain valve.
6. Undo drainpipe. Use appropriate size of spanner to remove drain valve.
7. Replace in reverse order and check for oil leaks.

4.7 FILTRATION PUMP (E3845 ‘F’ variants only)

1. Remove rear access panel. Disconnect pipe at filtration pump.
2. Disconnect electrical coupling plug and start capacitor connections.
3. Remove nuts from pump mounting bolts (accessed through fryer door at rear of oil bucket compartment) and lift pump clear.
4. Disconnect pump from bracket. Replace in reverse order.



Note:

Remember to check for oil leaks before replacing any panels.

4.8 TEMPERATURE LIMIT (safety) THERMOSTAT

1. Remove element box lid.
2. Undo phial retention nut.

3. Lift elements and secure in raised position.
4. Release phial from retaining clip.
5. Disconnect phial wire plug and cut off plug.
6. Pull down phial to remove.
7. Carefully replace in reverse order. Check for any oil leaks and that thermostat calibration is within specification.

4.9 CONTACTORS & FILTRATION PUMP TIMER

1. Remove six fixings from rear control compartment cover.
2. Disconnect wiring from faulty component, noting all connections.
3. Replace and rewire component.
4. Replace cover.

4.10 OIL LEVEL SENSOR (E3845 'X' variants only, Figure 8)

1. Ensure fry pot is empty.
2. Remove back panel.
3. Disconnect oil sensor wires (blue & red BNC connectors) from the evaluation unit.
4. Remove RH side panel.
5. Remove element box lid.
6. Carefully feed oil sensor wires (blue & red BNC connectors) up through element box legs into the element box.
7. Undo oil level sensor retaining nuts.
8. Pull the oil level sensor down into the pan and carefully feed the wires through the boss.
9. Carefully replace in reverse order.

4.11 TOP UP AND LOW OIL LEVEL LEDS (E3845 'X' variants only, Figure 8)

1. Remove control panel by undoing fixings at top and bottom of control panel. Disconnect control panel.
2. Remove electrical connections from LEDs. Undo LED retention nut.
3. Carefully replace in reverse order.

4.12 OIL LEVEL SENSOR EVALUATION UNIT (E3845 'X' variants only, Figure 8)

1. Remove back panel.
2. Disconnect oil sensor wires (blue & red BNC connectors) from the evaluation unit.
3. Disconnect evaluation unit wires (brown, blue, white & black) from relays and power supply unit.
4. Disconnect earth lead from chassis.
5. Remove evaluation unit from bracket by undoing fixings.
6. Replace in reverse order.

4.13 RELAYS & RELAY BASES (E3845 'X' variants only, Figure 8)

1. Remove back panel.
2. Disconnect wiring.
3. Remove relay and base from DIN rail.
4. Replace in reverse order.

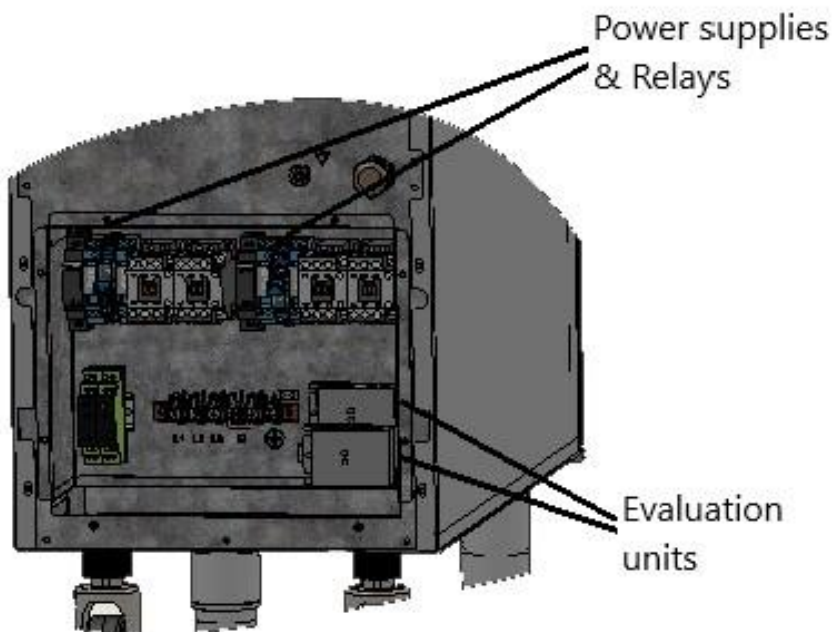
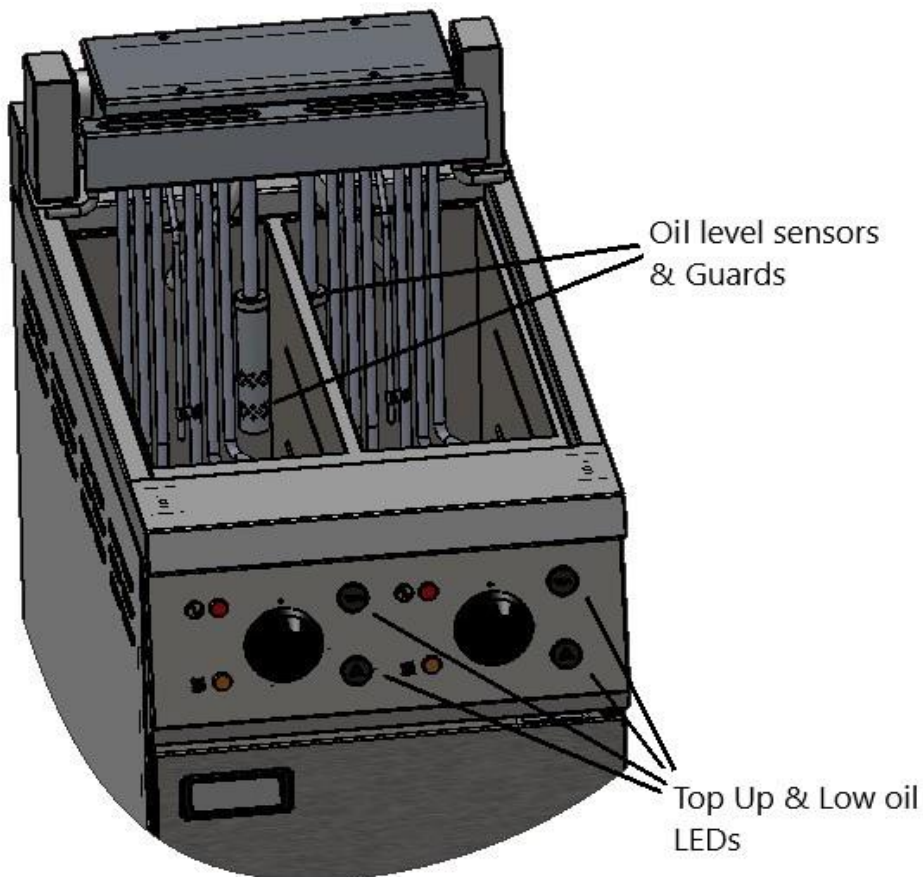

Figure 8 – Oil level sensor circuit components

5.0 SPARES

When ordering spare parts, always quote the appliance type and serial number. This information will be found on the data plate.

Operating Controller	Operating Controller Knob
Operating Controller Temperature Sensing Probe	Safety Thermostat
Programmable electronic controller	Ballast Resistor
Drain Valve	Fuse - 5Amp
Fuse - 2Amp	Amber Neon
Red Neon	Castor
Adjustable Leg	Pan Crumb Catcher
Chip Basket	Oil Pump Timer
Oil Pump	Fine Mesh Oil Filter
Oil Filter Basket	Evaluation unit
Oil level sensor	24VDC Relay
24V power supply	230VAC Relay

6.0 CRITICAL DIMENSIONS

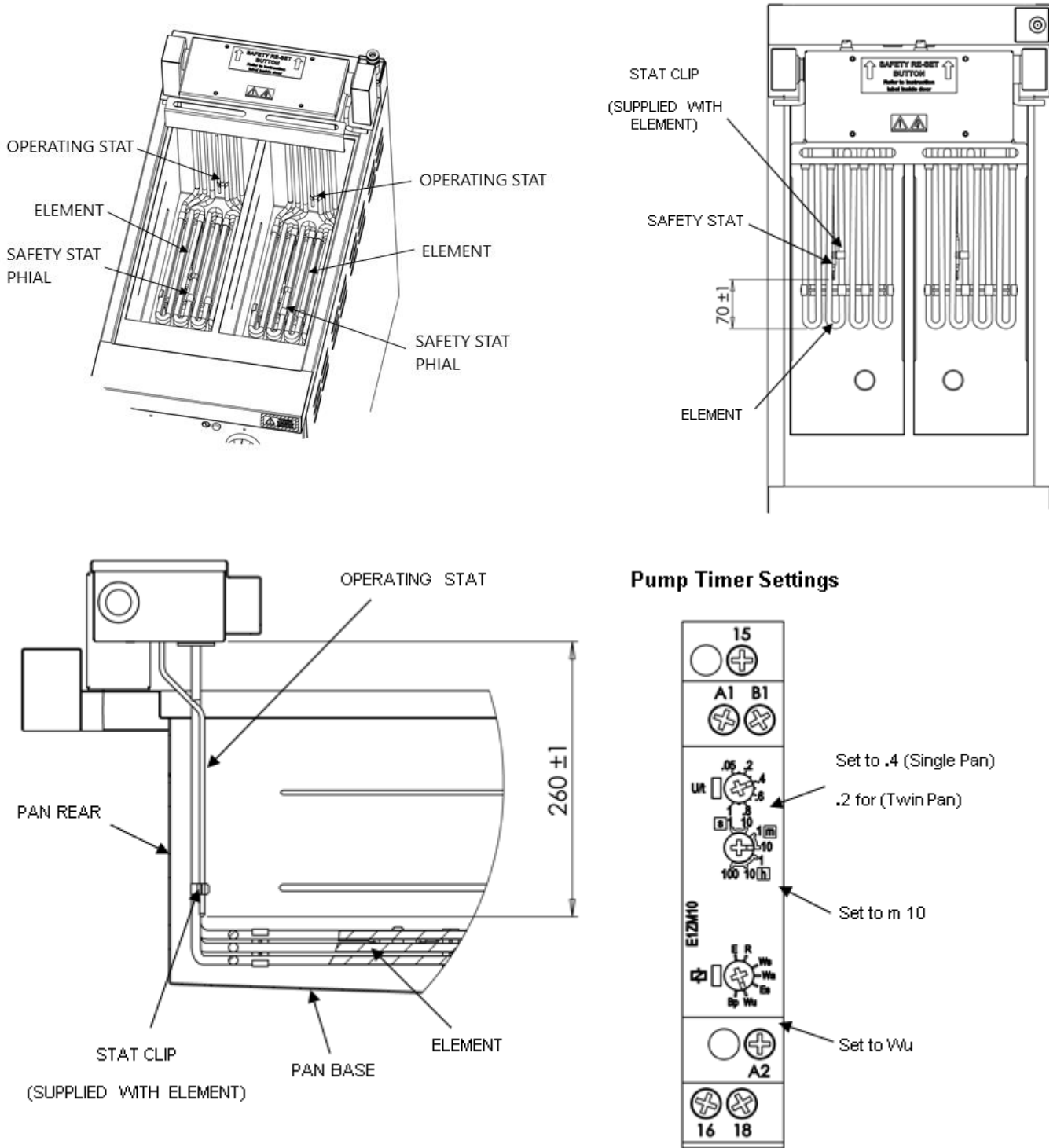

Figure 9 – Critical dimensions

7.0 OPERATING INSTRUCTIONS



PARTICULAR ATTENTION MUST BE PAID TO CLEANING THE THERMOSTAT PROBE AND CAPILLARIES. ENSURE FOOD DEBRIS DOES NOT BUILD UP, WHICH COULD DETRIMENTALLY AFFECT THE PERFORMANCE AND SAFETY OF THE APPLIANCE.



PARTS WHICH HAVE BEEN PROTECTED BY THE MANUFACTURER ARE NOT TO BE ADJUSTED BY THE USER.

The fryers are of twin pan type and the following units are covered by this manual.

E3845 – Manual control model.

E3845X – Manual control model with oil level sensor.

E3845F – Manual control model with built-in filtration.

E3845FX – Manual control model with built-in filtration and oil level sensor.

E3845F2 – Manual control model with built-in twin independent filtration.

E3845F2X – Manual control model with built-in twin independent filtration and oil level sensor.

E3845P – Four product key electronic control model.

E3845XP – Four product key electronic control model with oil level sensor.

E3845FP - Four product key electronic control model with built-in filtration.

E3845FXP - Four product key electronic control model with built-in filtration and oil level sensor.

E3845F2P - Four product key electronic control model with built-in twin independent filtration.

E3845F2XP - Four product key electronic control model with built-in twin independent filtration and oil level sensor.

Note: The oil container may be heavy. Drain small amounts at a time if necessary, before lifting container. Manual handling regulations should be observed.



Warning: Appliances on Castors

When the fryer is supplied with castors it should be connected to supply piping by means of a connector for moveable appliances. In addition, a restraining chain should be connected between appliance and wall. Ensure this restraint is re-connected when unit is returned to original position.



Moving the fryer with hot or cold oil in fry pot can be dangerous to the operator. Scalding could occur. Spilled oil or fat on the kitchen floor could cause slipping accidents and any such deposit should be cleaned up straight away.

To prevent any such hazard, DO NOT move fryer until all liquid has been drained from fry pot.

USE OF OIL / SHORTENING / SOLIDS (COOKING MEDIUM):

As these are highly flammable when in their liquid state, caution should always be taken when using cooking medium.

Recommendation:

PPE's (Personal Protective Equipment) should be used when cleaning or handling medium within this fryer.

Medium should not be overheated as this will increase the risk of fire.

Note: Fryer is fitted with a thermal safety device. This will stop heating of medium if the medium becomes overheated. This appliance will always fail safe.



Warning

This appliance should only be used with both oil temperature controlling Thermostat and Thermal limit (safety) Thermostat in working condition.

NEVER leave a working unit unattended. Medium must always be maintained within fry pot.

Cold Medium - when filling with cold medium (see Figure 8), DO NOT FILL MEDIUM PAST -MIN- LEVEL MARK (maximum cold fill mark) also, for Solid Medium - See Section 10.

— MAX —
— MIN —

-MIN- Level Mark: Medium should NEVER be allowed to drop below this mark. Should this occur, top up immediately or switch fryer OFF.



Hot Medium and Topping Up Medium DO NOT FILL MEDIUM PAST -MAX- LEVEL MARK (Maximum Hot Fill Mark). (See Figure 10).

Figure 10



CAUTION

SUITABLE PROTECTIVE CLOTHING MUST BE WORN when topping up whilst fat in fryer is hot.

Medium and Foodstuffs

As foodstuffs increase volume within fry pot - follow these rules:



DO NOT ADD WATER TO FRYING MEDIUM AT ANY TIME!

Do not introduce excessively wet food into the fryer.

WARNING

No attempt must be made to operate this appliance during a power supply failure. Please ensure that any plastic-coated items are removed prior to use. Before operation, pan requires to be thoroughly cleaned and dried.

Discolouration of heated parts is caused by factory testing to ensure unit is satisfactory. It will not affect quality or performance.

An electronic thermostat with temperature probe is fitted. The operating thermostat automatically controls oil temperature. The temperature limit thermostat ensures that the oil will not reach a dangerous temperature level.

If limit thermostat should activate during operation, an investigation to determine the reason must be carried out by a qualified technician.

7.1 APPLIANCE CONTROLS

Refer to Sections 3.3.1, 3.3.2, 3.3.3 and 3.3.4 for controls layout and description.

7.2 OPERATION Safety Precautions

The installer must fit an isolator switch on unit electrical supply.

The user **MUST** be familiar with location and operation of isolator switch for shutting off electrical supply in event of an emergency.

7.2.1 Fry Pot Filling Instructions

Remove lid (if fitted) and baskets and set these aside. Ensure pan is clean and completely dry. Ensure also that drain valve is closed. Pour clean, cold oil to - **MIN** - pan level mark on element guard/basket support grid.

7.2.2 Switching On

1. If unit has filtration, ensure filtration pump switch is in the 'OFF' position (O).
2. Press appropriate ON/OFF pan switch to ON position (I).
3. 'Check Oil Level' lamp will flash, and an alarm will sound. Operator **MUST** ensure that there is oil / sufficient oil in the pan (see Figure 6).
4. Once operator has satisfied themselves that there is the correct level of oil in the pan, press start button (see Figure 4). Controller will now be engaged (see Figures 2 & 3).

(E3845 non-'P' Models)

5. Turn knob to select temperature.
6. Heat demand indicator will illuminate.

(E3845 'P' Models)

7. Unit has a temperature range between 130°C to 190°C (See Section 7.3.1 for instructions on how to change set temperature).
8. Display will illuminate with figures 8888 for 2 seconds, CTT for 2 secs, r 02 for 2 seconds and Set Deg flashes Press ↓1 or 4↑ on control panel, last temperature will display, if temperature acceptable press <temperature button 3> to activate. If temperature is not acceptable see section 6.3 for instructions on how to change to set temp. When temperature is set Louu displays. Heat demand LED indicator will illuminate (small dot between L and O).

7.2.3 Fryer Maximum Basket Loading

Pre-blanched chilled fries – **2 x 1.5kg baskets.**
Frozen fries – **2 x 1.2kg baskets.**

7.2.4 Using the Controller

When unit has been switched on as detailed in Section 7.2.2, fryer may be operated as follows:

E3845/E3845F/E3845F2/E3845X/E3845FX/E3845F2X Models – Manually Operated

Oil temperature will be governed by controller temperature shown on control knob selected by user.

E3845P/E3845FP/E3845F2P/E3845XP/E3845FXP/E3845F2XP Models – Programmable

The oil temperature will be governed by controller at a temperature range of between 130°C to 190°C. See Section 7.3.1 for details of how to change set temperature.

When actual temperature is within 10°C of set point, display indicates **redy**. See Section 6.3 for details of how to display actual or set temperature.

Before carrying out any cooking operations, controller should be set up for a particular application of use (e.g., up to four timer programmes, product frying temperature, °C/°F). This can all be carried out using the following guide.

Operating the Controller:

1. **To start a timing cycle:** Press any product key (1 to 4) to start a timing cycle. If key is programmed, correct time will display and will immediately start to count down. LED above key will flash. **done** will display when cook cycle ends and alarm will sound. If **done** is displayed immediately and alarm sounds, key has not been programmed See Section 6.3.2 for programming details.
2. **To stop a timing cycle:** Press and hold an active product key for 3 seconds or press key 3 times within 2 seconds.
3. **Respond to a done alarm:** Cancel signal by pressing same product key used to start timing cycle.
4. **Multiple timing cycles:** If a second or third product key is pressed while first is still active, shortest time remaining key is displayed and only LED above key flashes, other(s) remain constantly lit. Once shortest time programme ends and is accepted, next shortest is displayed and LED above flashes. **Note:** All product key timers will count down although not displayed until shorter one ends.
5. **Action alarms (shake, etc.):** If control is programmed for action alarm, this will signal at a pre-set time during timing cycle. The signal, a dual-rhythm beeping, will last 5 seconds and then self-cancel. The display will flash action alarm time and will continue counting towards **0:00**.
6. **Viewing Actual / Set Temperatures:** Press temperature key once to display "**AXXX**" where XXX is actual temperature (°C or °F depending on controller programming, see Section 6.3.1). Press temperature key again within 5 seconds to display "**PXXX**" where XXX is programmed set temperature controller (°C or °F depending on how controller is programmed – See Section 6.3.1). If temperature key is not pressed again within 5 seconds, display returns to idle or timer mode.

7.3 PROGRAMMING THE CONTROLLER - Display Descriptions

- **Louu:** Controller is in operating mode. Actual vat temperature is more than 10°C below programmed vat temperature.
- **rEdy:** Controller is in operating mode. Actual vat temperature is within proper cooking temperature range. The vat is ready to start a cook cycle.
- **HI:** Controller is in operating mode. Actual vat temperature is more than 10°C above programmed vat temperature.
- **Prob:** Control probe is either open circuited or short circuited. Display will be accompanied by an audible alarm if shorted. Check or replace probe.
Note: If **Prob** is displayed on the controller display, the elements cannot be energised.
- **X:XX (X = Number):** The control is in operating mode and a cook cycle is in progress.
- **done:** The control is in operating mode and a cook cycle has been completed. Display will be accompanied by a pulsing audible alarm.

7.3.1 Programming temperature set point and temperature scale (range available is between 130°C to 190°C).

1. Press and hold temperature key for 3 seconds. "Prog" will be displayed. Then press DOWN (key 1) or UP (key 4) key.
2. The display will show either "°C" or "°F" (degrees Celsius or degrees Fahrenheit). Once desired temperature scale is displayed, press temperature key to accept / enter.
3. Display will now alternate between "Sett" and "XXXZ" (where X denotes temperature and Z indicates temperature scale).
4. Adjust temperature using DOWN (key 1) and UP (key 4) keys. The longer key is pressed, the faster temperature scrolls.
5. When desired temperature has been reached, press temperature key to accept / enter.
6. To exit temperature programming, press temperature key again.

7.3.2 Programming a Product Cycle Time and Action Alarm

1. Press and hold P key for 3 seconds. "Prog" will be displayed. Note: Programming mode will exit automatically if no keys are pressed within 2 minutes.
2. Select a product key to program (1 to 4). The display will alternate between "ti-z" and "X:XX" where z is the number of key pressed and X:XX is set time in minutes and seconds.
3. Adjust the time up or down using the DOWN (key 1) and the UP (key 4) keys. The longer key is held, the faster time will scroll.
4. When set time is reached, press P key to accept / enter.
5. The display will now alternate between "PrEz" and "X:XX" where z is number of key pressed and X:XX is action alarm time in minutes and seconds.

Note: The time entered here is time action required before end of total cycle time entered above. If NO action time is required, leave at "0:00". Adjust time as c) above.

6. Once desired time is reached, press P key to accept / enter.
7. "Prog" will again be displayed and another product key can be selected for programming. Repeat above steps. When no more keys are required to be programmed and "Prog" is displayed, press P key to exit programming mode and return to idle mode.

8.0 CHANGING THE OIL



Warning

After filtering, wait 30 seconds before removing bucket.

It is dangerous to use shortening that is too old. This medium has a reduced flash point temperature and is prone to surge boiling.



Caution

To prevent surge boiling, **DO NOT EXCEED** recommended loads or charge the pan with over-wet food items. **NEVER LEAVE** a working appliance unattended



Warning

When draining solids/shortening, ensure oil has time to strain through strainer basket. Heavily unfiltered oil may overflow.

Note: This could cause pump to block over a period of time and is considered as misuse of equipment.



Warning

When pumping solids/shortening back into fryer pan. Ensure all trace of solids/shortening is emptied from receptacle (bucket).

If oil is not emptied on a regular basis or if oil is left in the receptacle, it may solidify and overflow or spill on to the kitchen floor to create a hazard.

8.1 STARTING THE FILTRATION PROCESS

1. Turn unit off at ON/OFF switch and allow oil to cool below 170°C (or if cold, heat to minimum temperature of 60°C). Pull filter bucket forward.
2. Ensure bucket is clean and emptied of all oil and debris. Refer to Section 8 for details of how to clean filter components.
3. Ensure strainer and microfilter are clean and dry.
4. With strainer and microfilter in position, slide bucket back on to runner cradle and back into fryer to engage with pump.



Please Note – Warning

Do not handle filter components or adjacent surfaces when pump is operating. Components will remain hot for a period after filter. Allow cooling. Use of PPE's is recommended.

8.1.1 E3845F/E3845F2/E3845FX/E3845F2X/E3845FP/E3845F2P/E3845FXP/E3845F2XP models only

Note: With cabinet door open, filter pump switch is in centre of control panel. Refer to Figure 4.

1. Ensure appliance pan on/off switches are in OFF position.
2. Allow oil to cool for approximately 15 - 20 minutes.
3. Position bucket and filters and ensure these are clean and dry.
4. Open drain valve.
5. Allow oil to drain from pan.
6. Remove element guard from pan.
7. Raise elements with the aid of element lifting tool.



Please note: Elements and guard will still be hot!

8. Remove any frying debris from pan.
9. Lower elements.
10. Ensure oil return pipe is in quick-release valve housing and is projecting into desired pan (E3845F/E3845FX/E3845FP/E3845FXP Only).
11. Activate oil pump by means of filter pump switch to return oil to pan.
12. Leave to cycle for a few minutes before closing drain valve.
13. Allow pan to fill with oil.
14. Once oil has been returned to pan, switch the oil pump off by means of filter pump switch.
15. Replace element guard.
16. Top up oil to correct level.



Warning

Ensure all shortening has been pumped from receptacle before topping up pan.



Please Note

If the E3845X/E3845FX/E3845F2X/E3845XP/E3845FXP/E3845F2XP pan has not been refilled until at least the low oil level indication (Flashing hazard triangle) clears, then the elements will not switch on.

9.0 CLEANING and MAINTENANCE



BEFORE ANY CLEANING IS UNDERTAKEN, ISOLATE APPLIANCE FROM MAINS POWER SUPPLY AT ISOLATOR SWITCH.

SUITABLE PROTECTIVE CLOTHING MUST BE WORN WHEN CLEANING THIS APPLIANCE.

NEVER PUMP WATER THROUGH THE FILTRATION PUMP AT ANY TIME! WATER AND HOT OIL ARE AN EXPLOSIVE MIXTURE.

OIL MUST BE ALLOWED TO COOL TO A SAFE TEMPERATURE BEFORE DRAINING. DO NOT OVERFILL OIL BUCKET. ALL SPILLS ONTO THE PRODUCT AND ON THE FLOOR SHOULD BE CLEANED UP IMMEDIATELY.

THE APPLIANCE MUST NOT BE CLEANED WITH A JET OF WATER OR BE STEAM CLEANED. DO NOT USE ACID OR HALOGEN-BASED (E.G. CHLORINE) DESCALING LIQUIDS, FLAMMABLE LIQUIDS, CLEANING AIDS OR CLEANING POWDERS.

FAILURE TO CLEAN AND CHECK THE SAFETY AND OPERATIONAL THERMOSTATS CAN IMPACT THE PERFORMANCE OF THE APPLIANCE AND INCREASE THE RISK OF AN APPLIANCE FIRE.

FAILURE DUE TO LACK OF PROPER CLEANING IS NOT COVERED BY WARRANTY.

Note: All surfaces are easier to clean if spillage is removed before it becomes burnt on, cleaned daily.

Stainless Steel Surfaces

It should be noted that certain scouring pads including nylon types, could easily mark stainless steel. Care should be exercised during cleaning process.

When rubbing stainless steel with a cloth, always rub along in grain direction.

The following procedure should be undertaken, **AT LEAST DAILY**.

9.1 CLEANING THE APPLIANCE

Unit should be switched OFF and fry pot drained of oil.

1. Carry out actions as detailed in Section 9.
2. Switch unit off and drain oil from appropriate pan.
3. Remove baskets and element guard. Soak these components in hot soapy water.
4. Raise elements using tool provided (located behind unit door). Rest elements on rear support bar.
5. With drain valve open, remove any traces of debris from fry pot using a clean, damp cloth.
6. Remove strainer and microfilter, soak these in hot soapy water.
7. Wash, rinse, and dry removed items thoroughly. Set these aside.
8. Close drain valve.

9. Fill fry pot 3/4 full with hot water.
10. Clean pan using a soft, clean cloth and hot soapy water, rub away any stubborn staining with a scouring pad and suitable detergent.
11. Clean the elements, the safety and operating thermostats removing any food debris from around the thermostats which could detrimentally affect the performance and safety of the appliance.

TAKE CARE WHEN CLEANING NOT TO DISLODGE OR DAMAGE THERMOSTAT PROBES MOUNTED ON THE ELEMENTS.



DISLODGING OR DAMAGING THE THERMOSTAT PROBES OR THEIR CAPILLARIES CAN INCREASE THE RISK OF OVERHEATING OR FIRE.

IF THE THERMOSTATS OR CAPILLARIES ARE DAMAGED THEN DO NOT TURN THE APPLIANCE ON. CONTACT FALCON OR YOUR APPROVED SERVICE PROVIDER TO UNDERTAKE THE NECESSARY REPAIRS.

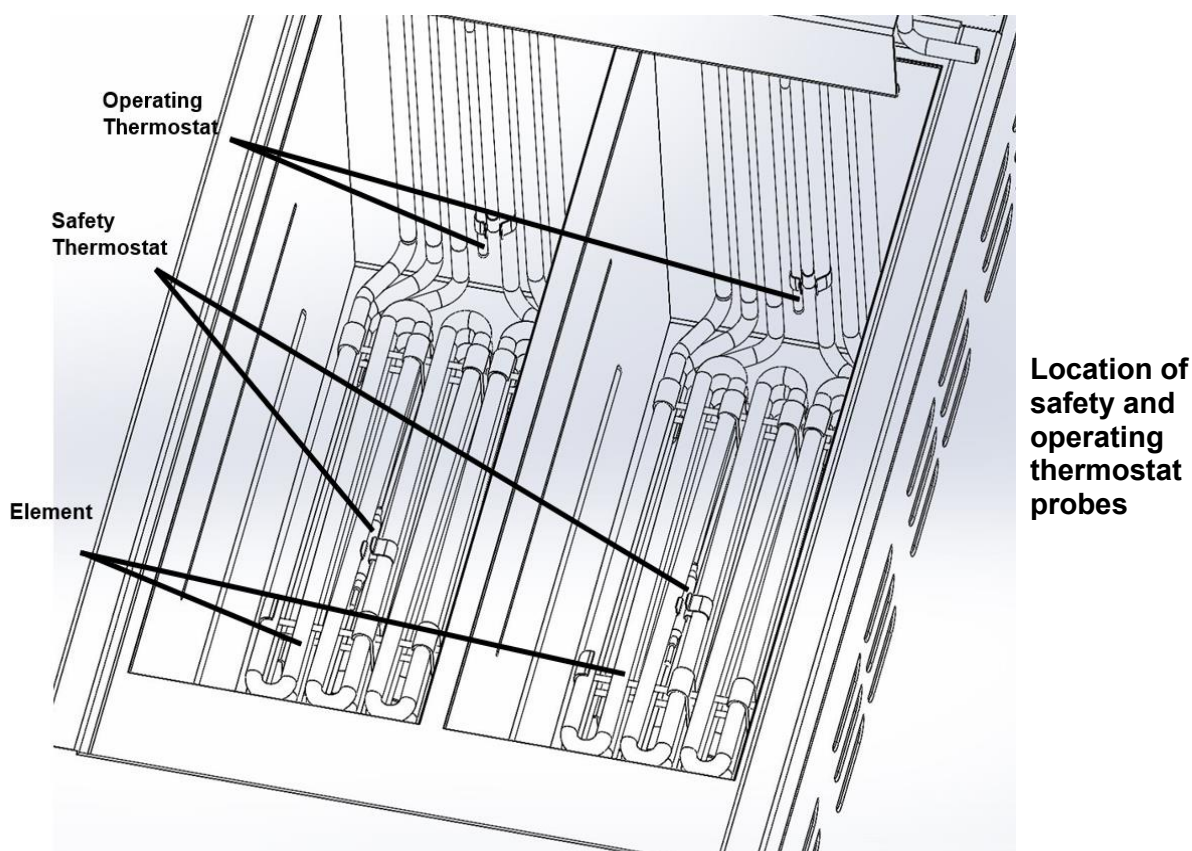

12. Slide up the oil level sensor guard ('X' variant models only).

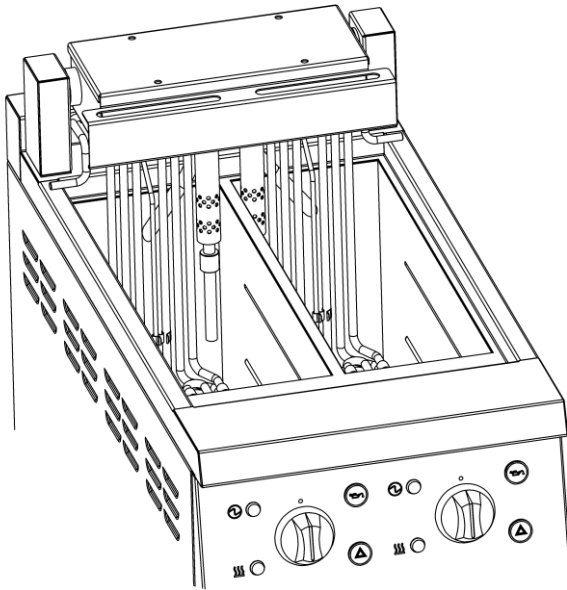

Oil level sensor guard raised for cleaning.

13. Clean guard and sensor using a soft, clean cloth and hot soapy water ('X' variants only).

Note: Care should be taken not to damage the oil level sensor probe located at the rear of the pan.

14. Remove bucket containing oil and replace with a suitable container for water.

15. Open drain valve. Allow water to drain into container below.

16. Use clean water to rinse fry pot and dry thoroughly.

17. Close drain valve.

18. Lower elements back into fry pot and replace element guard and baskets.

19. Slide down oil level sensor guard ('X' variants only).

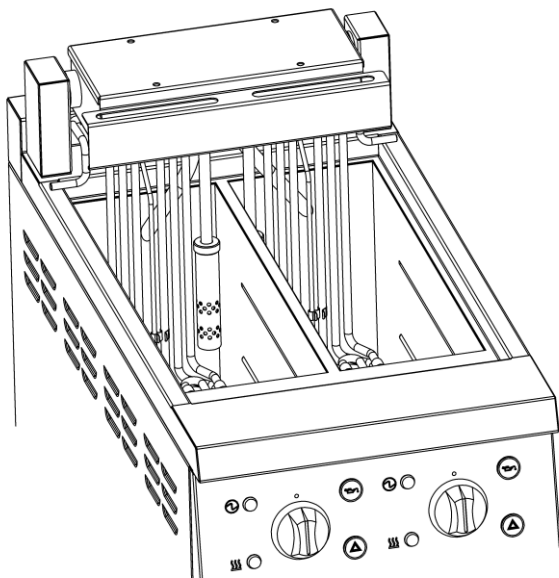

Oil level sensor guard lowered.

20. Pour away soiled water.

21. Discard used oil and thoroughly wash, rinse and dry bucket and oil suction pipe.

22. Replace strainer and micro-filter in oil bucket and return oil bucket to cradle.

23. Fill fry pot with clean oil to - MIN - mark. (See Figure 10).

10.0 PREPARATION OF MEDIUM

COOKING HINTS

Allow approximately 6 minutes for unit to heat up from cold to required operating temperature.

Choice of Frying Medium

Select a top-quality medium to obtain optimum results. Shortening or solid fats can be used if necessary. Solid fats **MUST** be heated carefully. Solid fat has a lower smoke point temperature than shortening.

All E3845 non-'P' variants: fat melt cycle pulses heat into the fryer.

A quality shortening is a more stable frying medium. It allows longer periods of use without smoking or foaming and will also give food a better flavour. Quality shortening has a higher flashpoint temperature and will reduce gumming around the appliance.

Regular filtering will help improve lifespan of the medium.



WARNING
NEVER MIX SHORTENING AND SOLID FAT!

Charging the Pan

Prior to operation, clean fry pot out using hot water and detergent. Rinse out and dry thoroughly. Ensure drain valve is closed. Fill fry pot with cold medium to - MIN - level mark on element guard. Maximum oil level capacity is 2 x 10 litres.

Solid Fat

If solid fat is to be used, remove element guard. Cut fat into small pieces. Place 9.2kg in each fry pot and pack it down. Position element guard on top of fat. Ensure FAT MELT CYCLE (E3845 non-'P' variants only) is selected for this process.

Note: The element guard will lower slowly as solid fat melts.

WARNING



If fish plate does not sit flat, lift plate from center slightly and lower carefully to ensure that no splashing of hot shortening occurs.

Check that correct shortening level is achieved when all solid fat has melted. Required temperature may then be set.

Solid fat should always be heated this way to prevent overheating and burning.



WARNING

It is dangerous to use shortening that is too old. Such shortening has a reduced flash point temperature and is prone to surge boiling.



CAUTION

To prevent surge boiling. **DO NOT EXCEED** recommended loads or charge pan with over-wet food items. **NEVER** leave a working appliance unattended.

Check that correct shortening level is achieved when all solid fat has melted. The required temperature may then be set.

Solid fat should always be heated this way to prevent overheating and burning.

11.0 COOKING HINTS

Frying food involves many variables and the following information is a guide only.

1. Ensure frying medium is clean and free of debris.
2. When topping up with oil, ensure oil level does not exceed - **MIN** - when cold and - **MAX** - line when hot.
3. Never overfill baskets with food product.



Warning ('X' variants only)

Do not pour food stuffs directly onto the oil level sensor guard, as this may affect the performance of the oil level sensor.

4. Filter oil as often as is practically possible. Remember, this can be done whilst oil is below 180°C.
5. It is advised that a skimmer is used continuously between frying batches of food to remove any floating debris. Failure to do this may result in oil becoming bitter to taste.
6. During quiet spells, it is recommended that thermostat is turned down to a lower setting. This will conserve energy in addition to extending expected oil life.
7. To ensure a good eating experience, fry food as close to serving time as possible.
8. After serving and when fryer has been turned off, replace lid to ensure that no foreign bodies can contaminate frying medium.

12.0 WIRING DIAGRAMS

12.1 E3845 Front Wiring Diagram

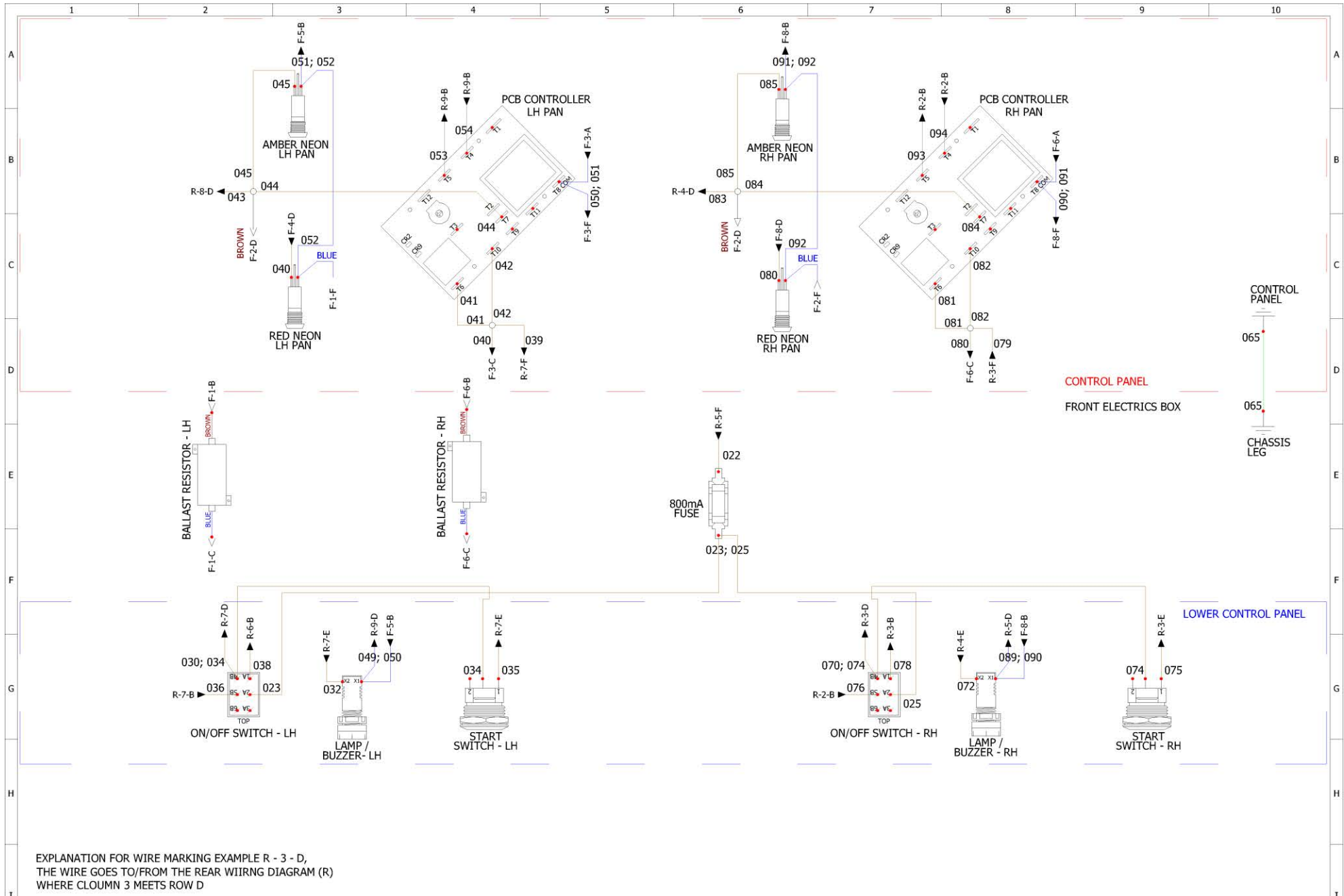

EXPLANATION FOR WIRE MARKING EXAMPLE R - 3 - D,
 THE WIRE GOES TO/FROM THE REAR WIIRNG DIAGRAM (R)
 WHERE CLOUWN 3 MEETS ROW D

12.3 E3845 Circuit Diagram

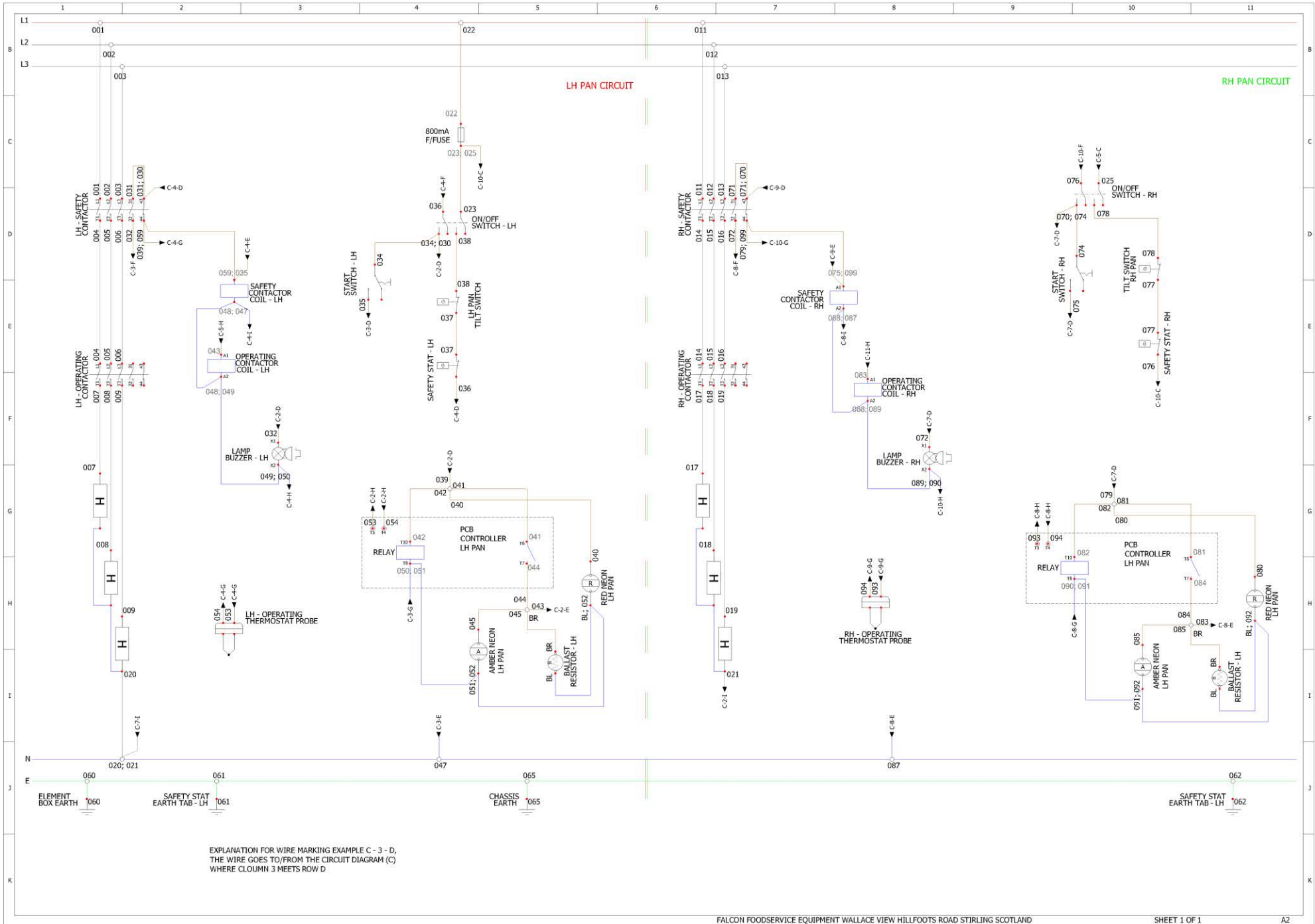

12.4 E3845X Front Wiring Diagram

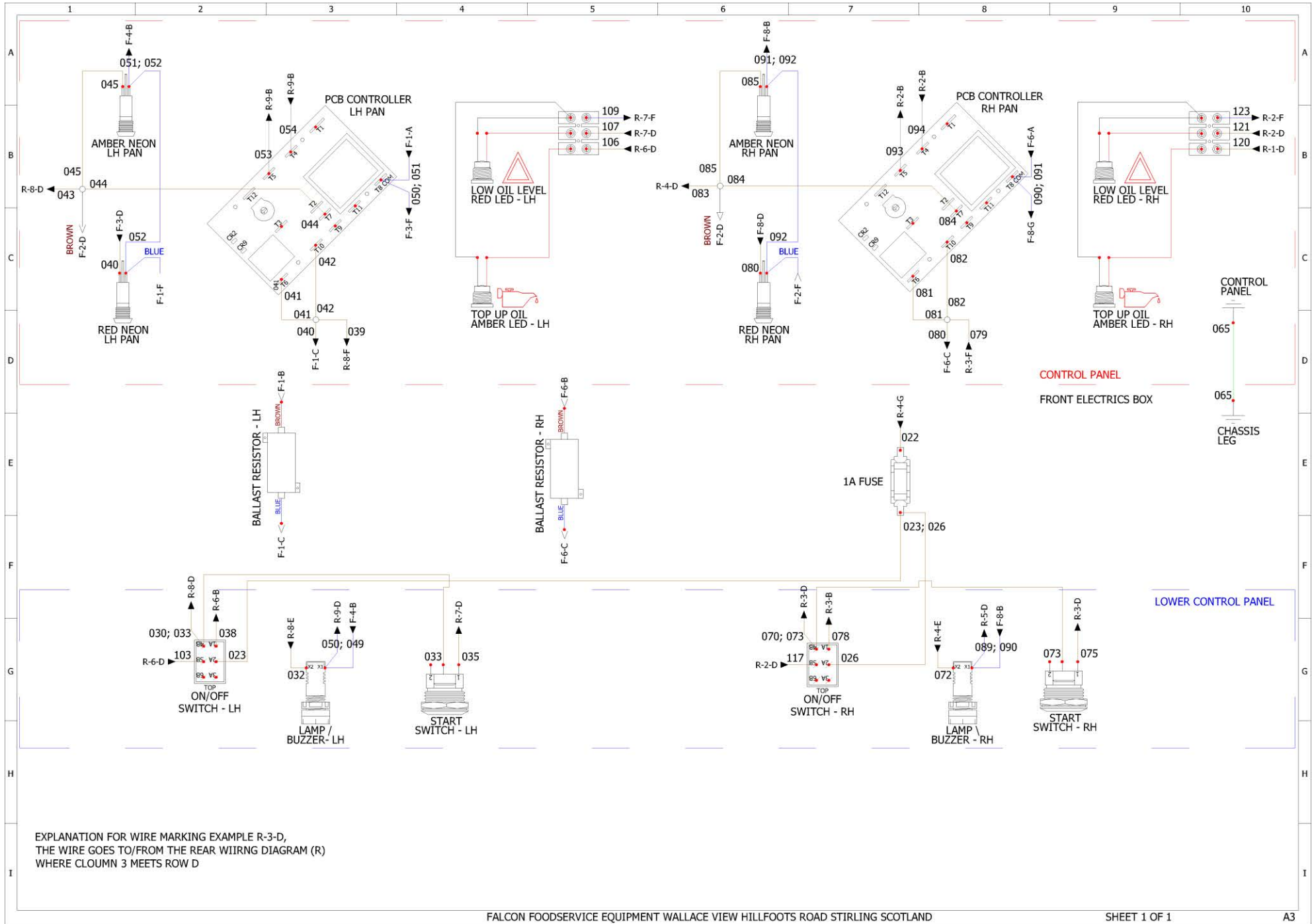

12.5 E3845X Rear Wiring Diagram

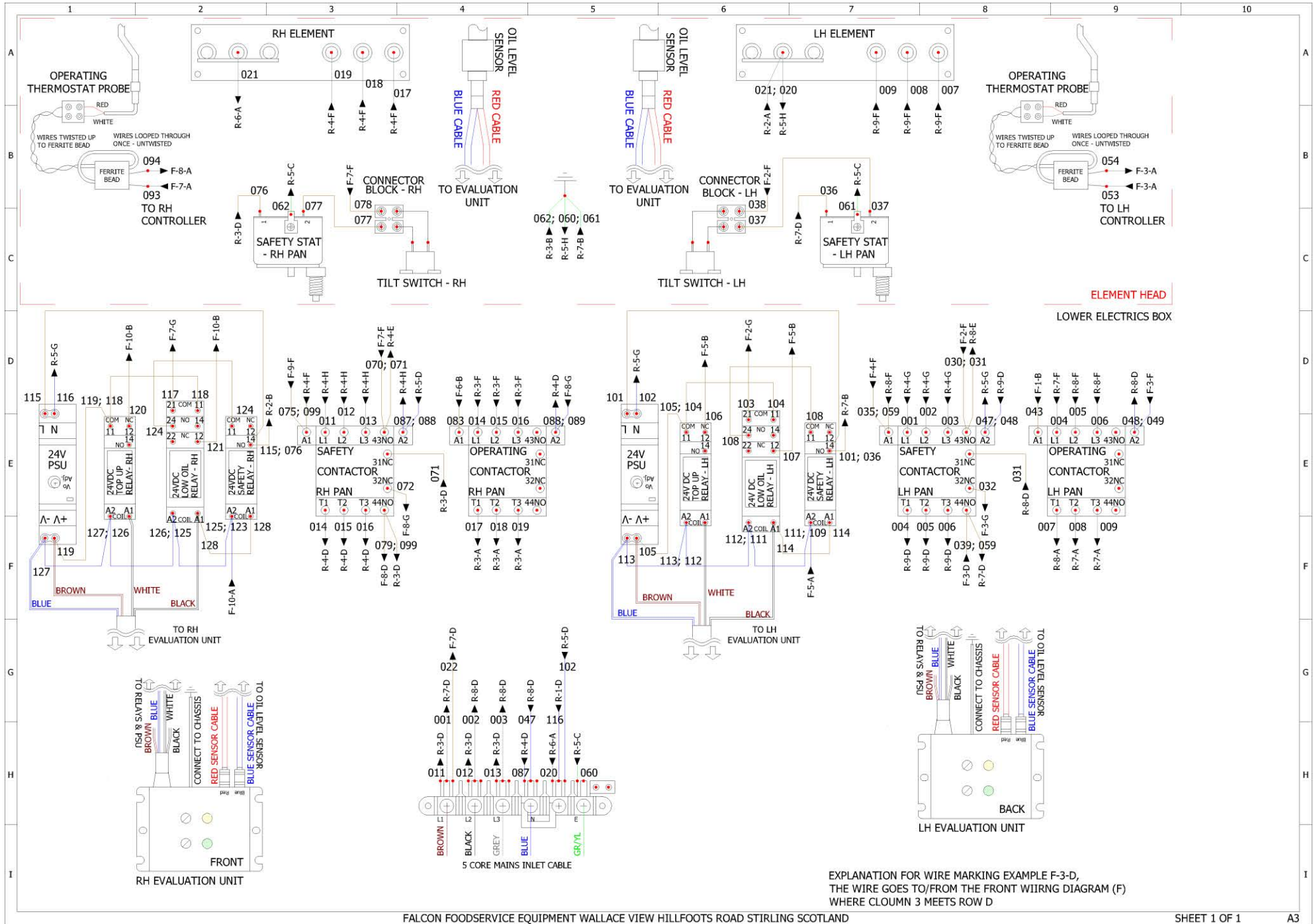

EXPLANATION FOR WIRE MARKING EXAMPLE F-3-D,
 THE WIRE GOES TO/FROM THE FRONT WIIRNG DIAGRAM (F)
 WHERE CLOUMN 3 MEETS ROW D

12.6 E3845X Circuit Diagram

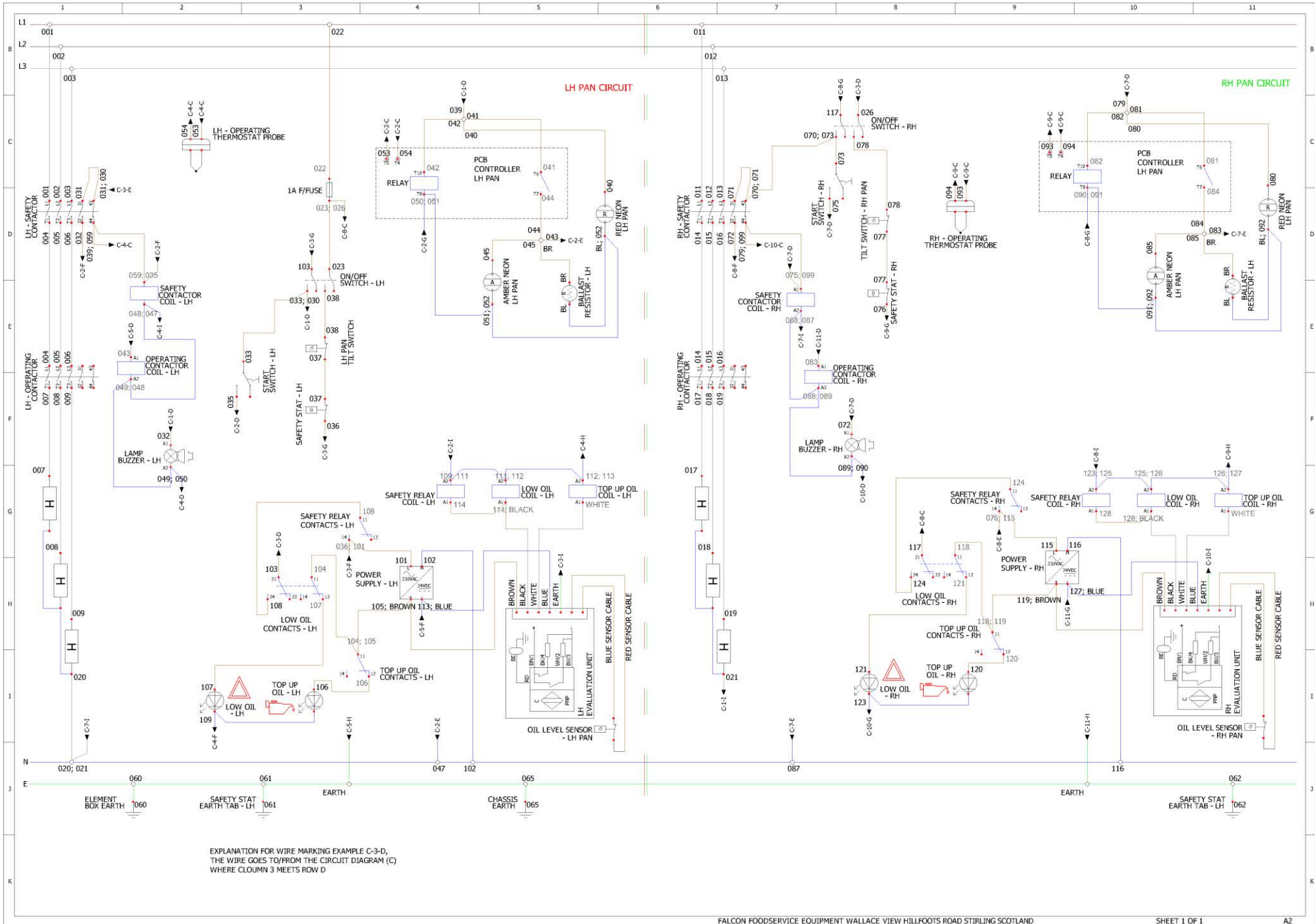

12.7 E3845F Front Wiring Diagram

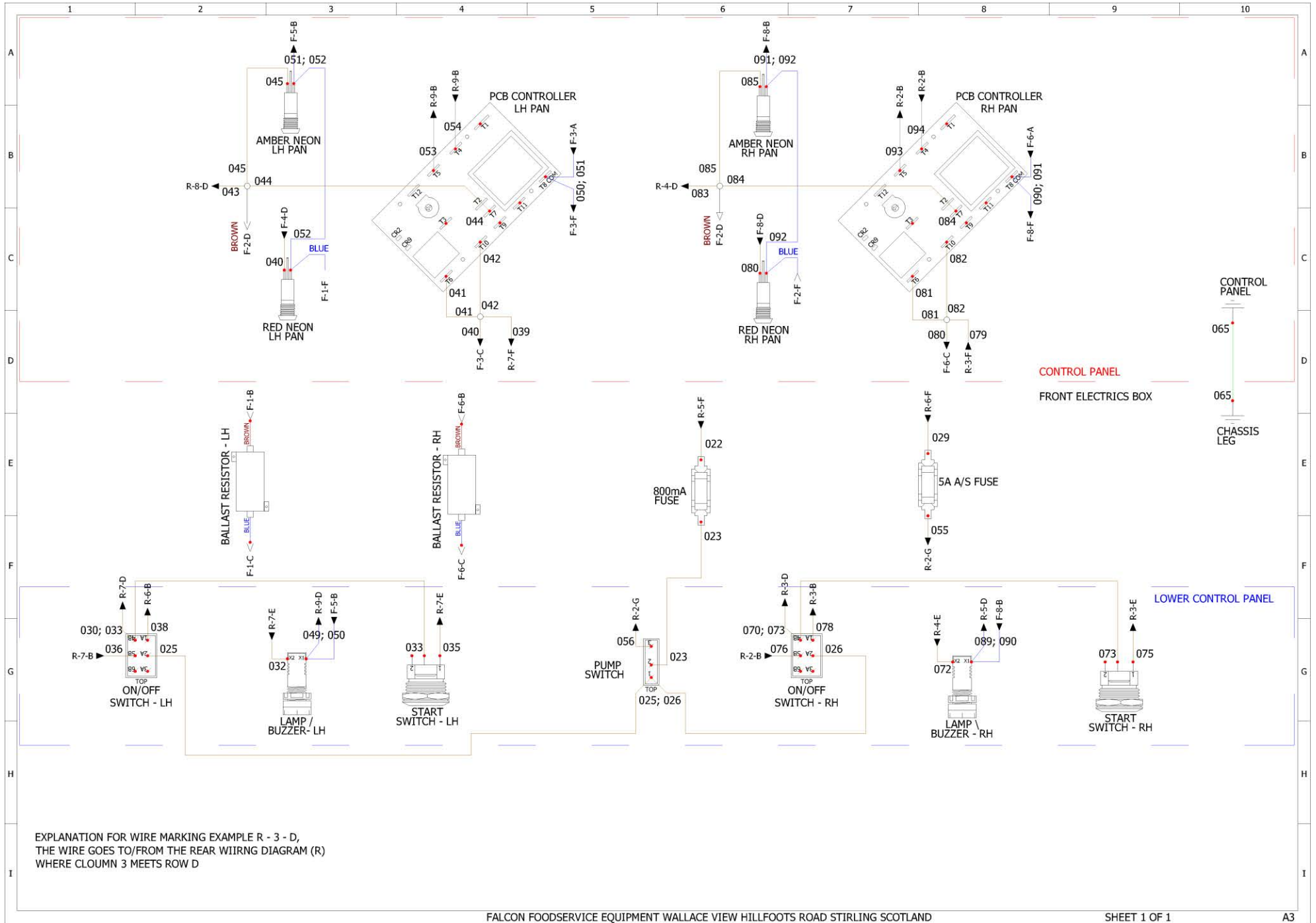

12.8 E3845F Rear Wiring Diagram

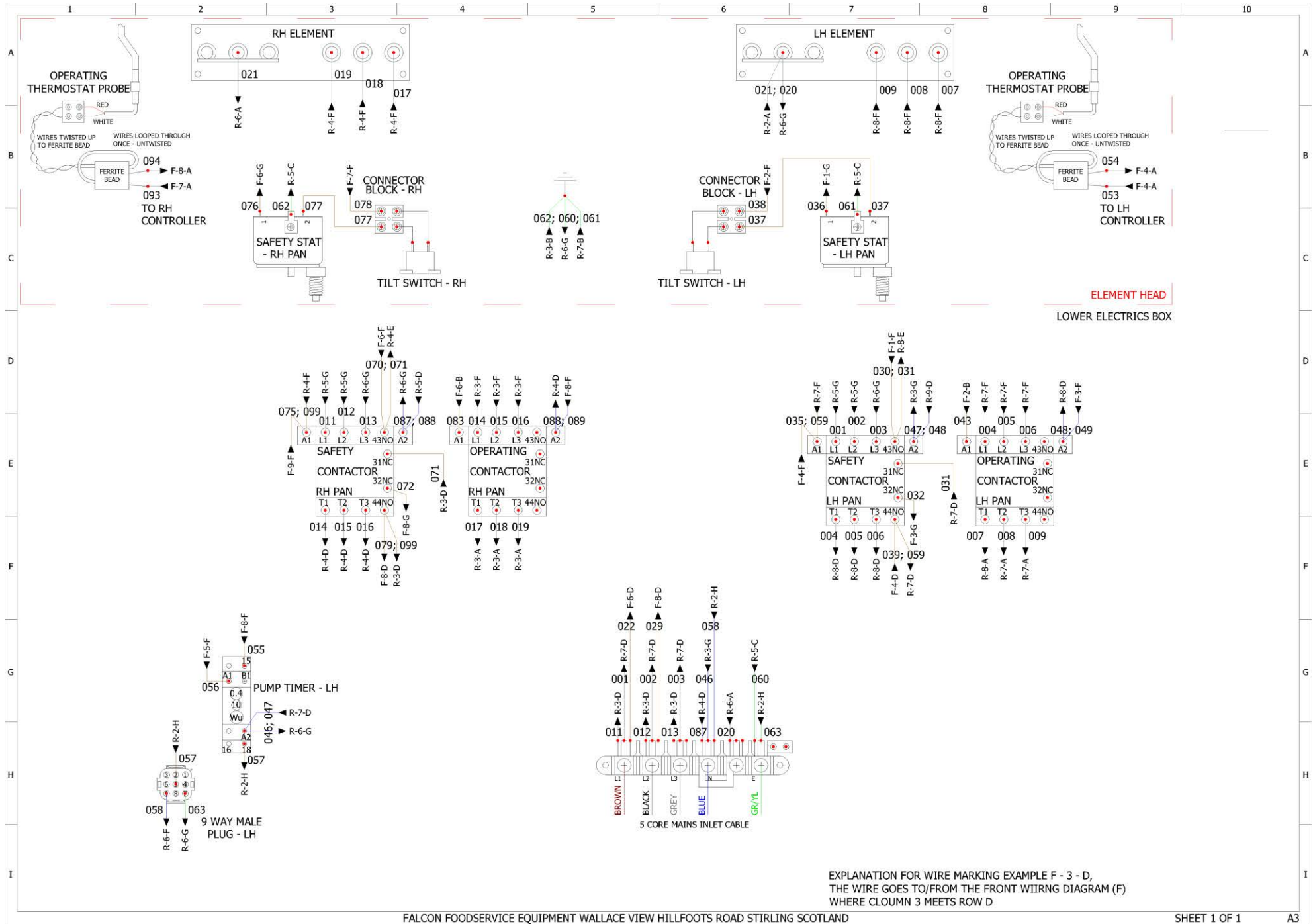

12.9 E3845F Circuit Diagram

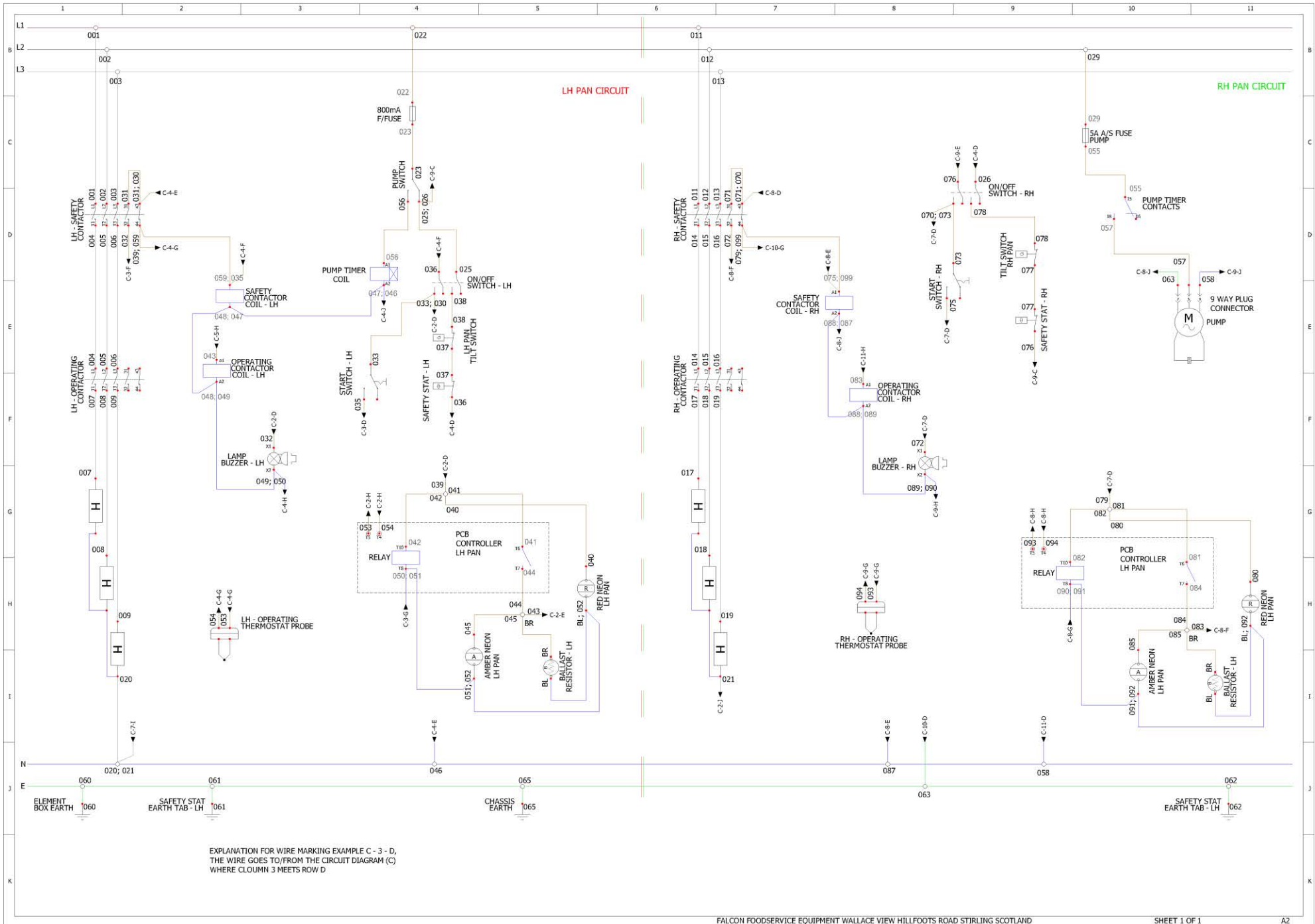

12.10 E3845FX Front Wiring Diagram

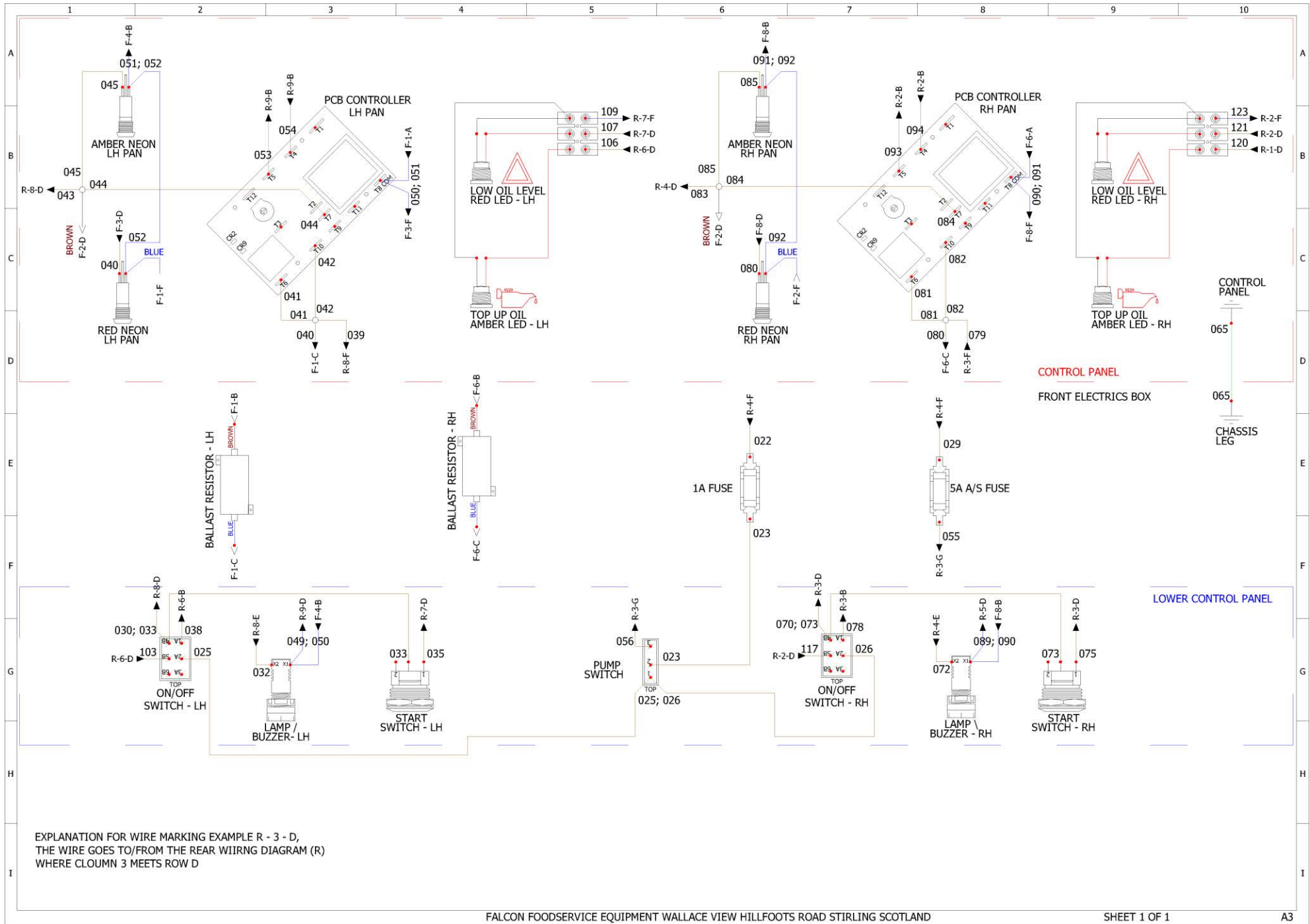

12.11 E3845FX Rear Wiring Diagram

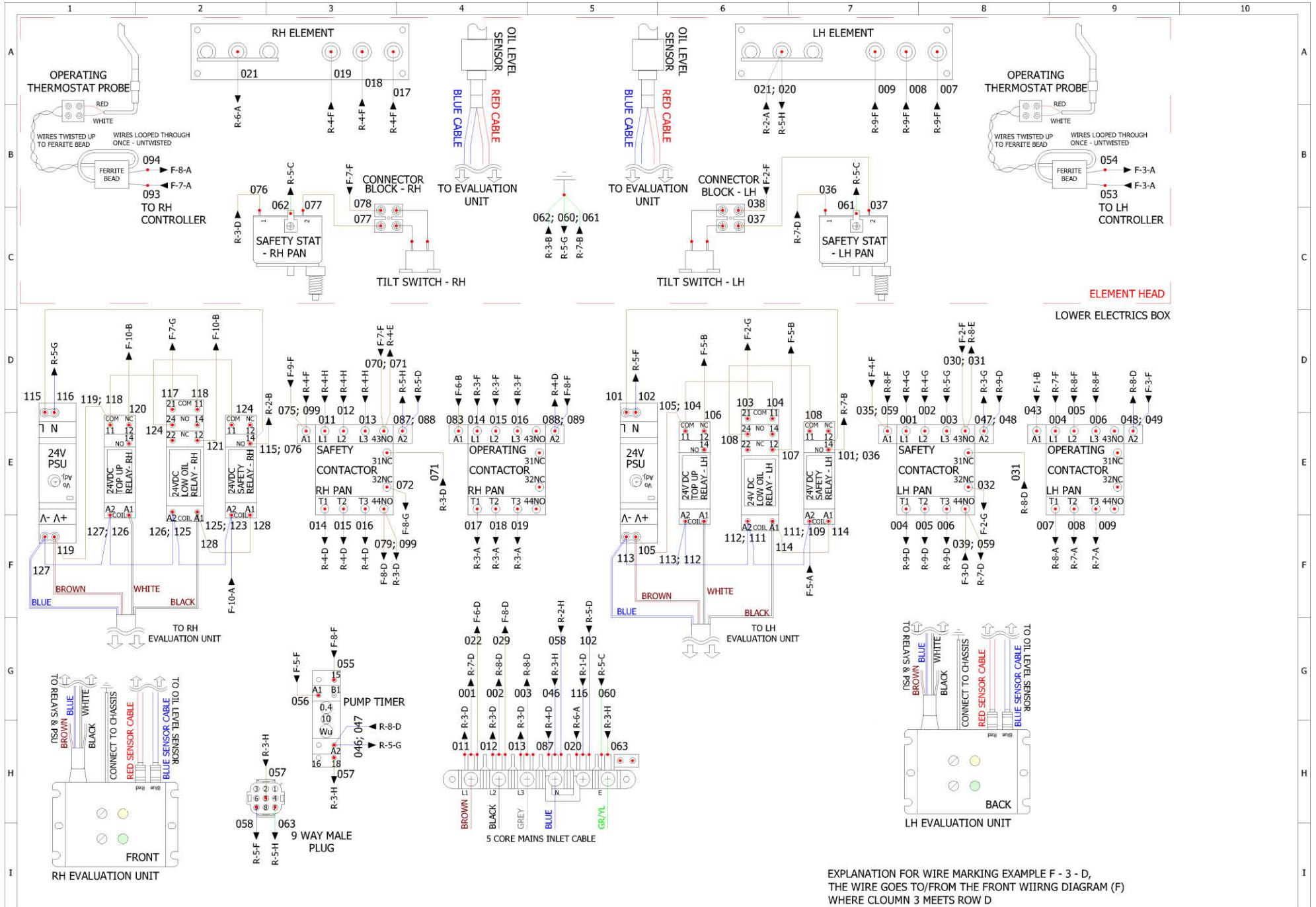

EXPLANATION FOR WIRE MARKING EXAMPLE F - 3 - D,
 THE WIRE GOES TO/FROM THE FRONT WIIRING DIAGRAM (F)
 WHERE CLOUMN 3 MEETS ROW D

12.12 E3845FX Circuit Diagram

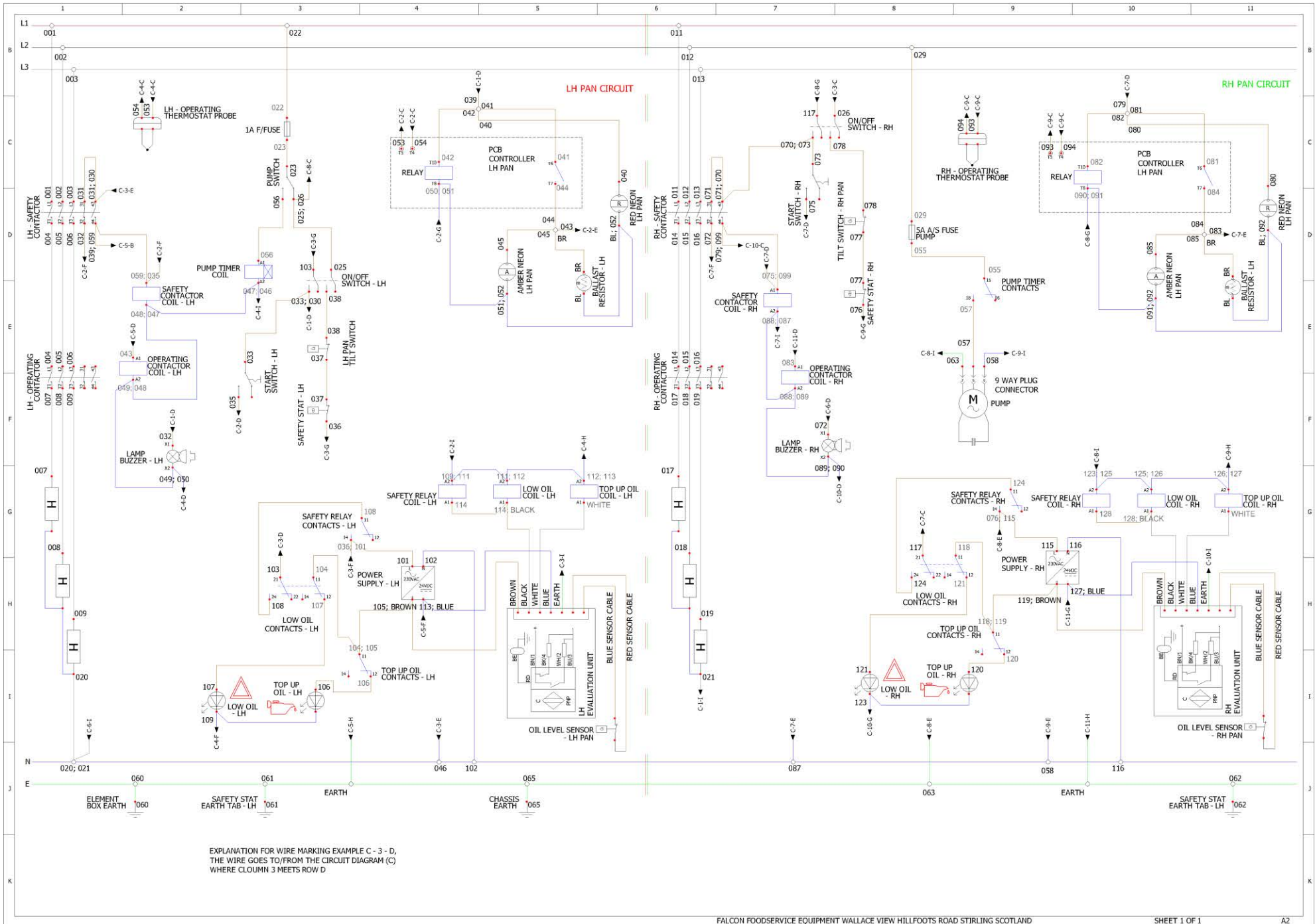

12.13 E3845F2 Front Wiring Diagram

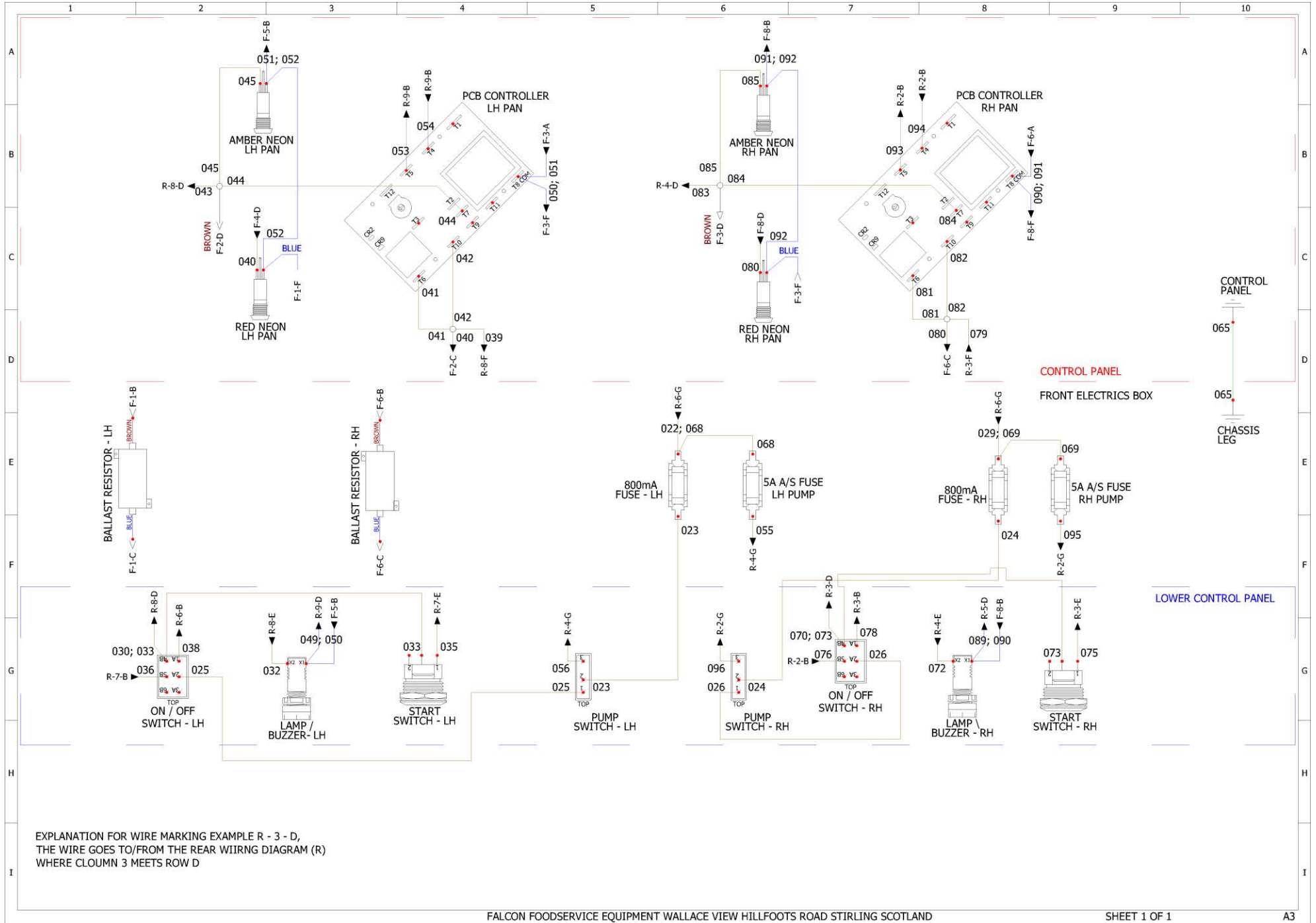

12.14 E3845F2 Rear Wiring Diagram

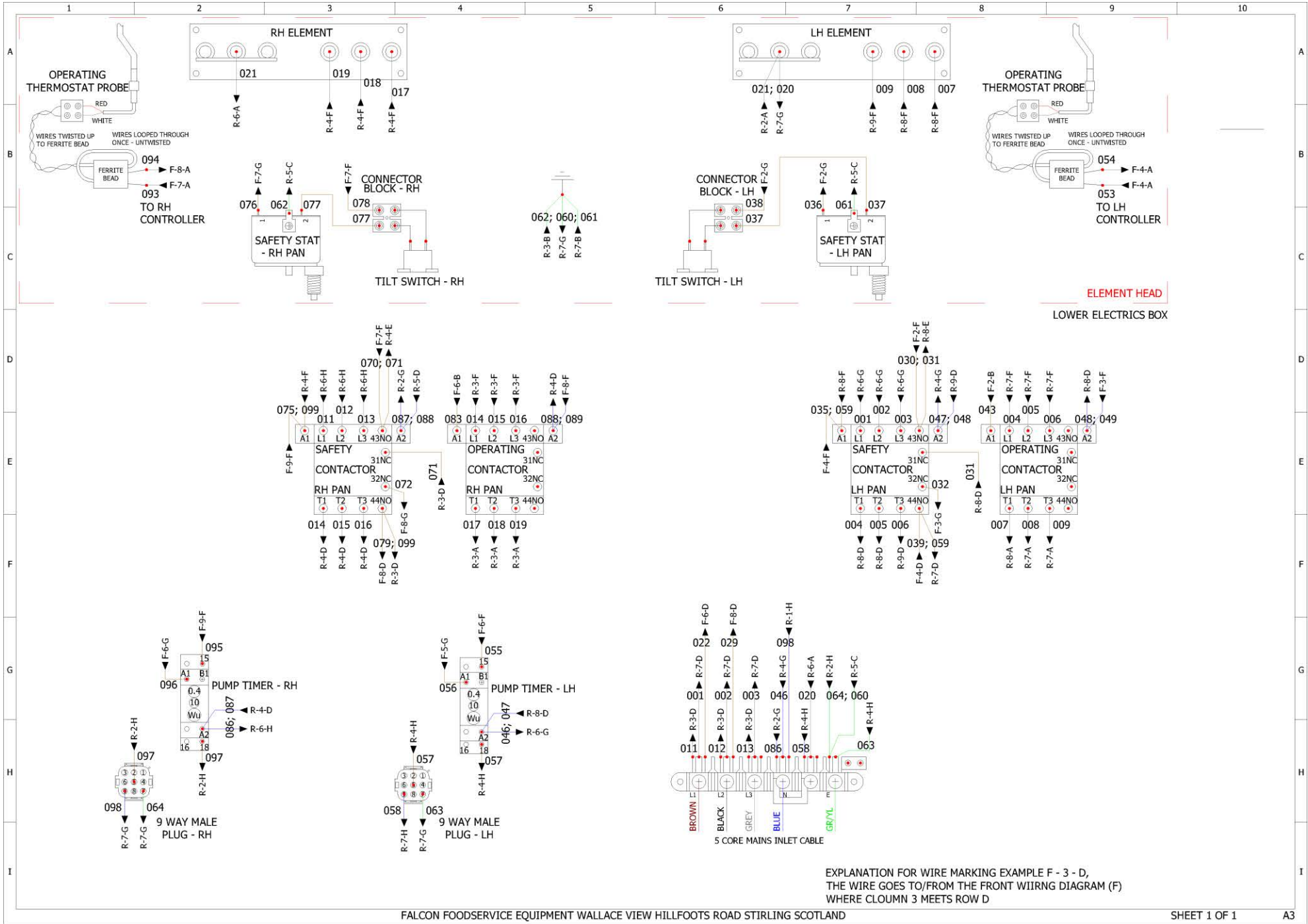

EXPLANATION FOR WIRE MARKING EXAMPLE F - 3 - D,
 THE WIRE GOES TO/FROM THE FRONT WIIRING DIAGRAM (F)
 WHERE COLUMN 3 MEETS ROW D

12.15 E3845F2 Circuit Diagram

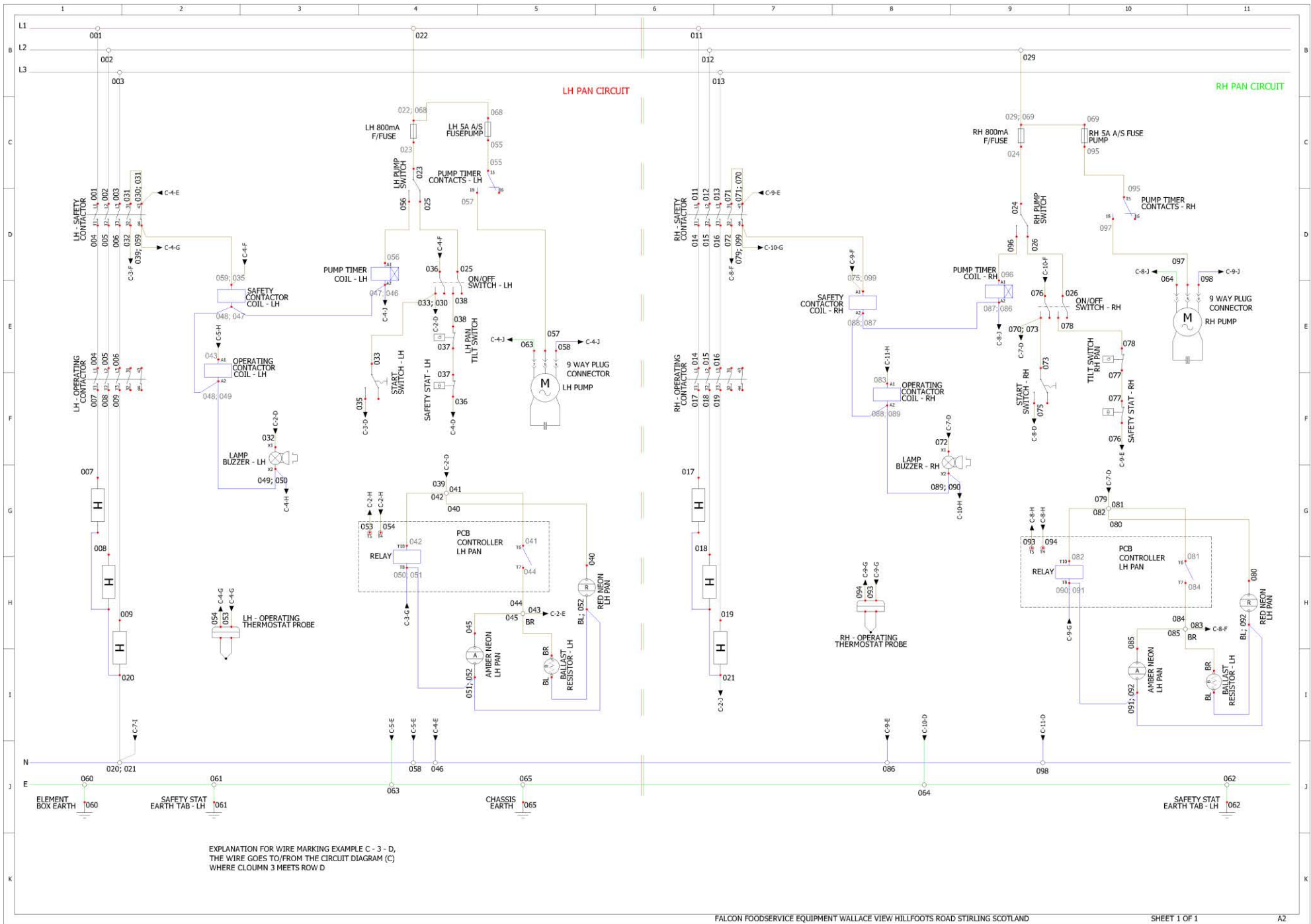

12.16 E3845F2X Front Wiring Diagram

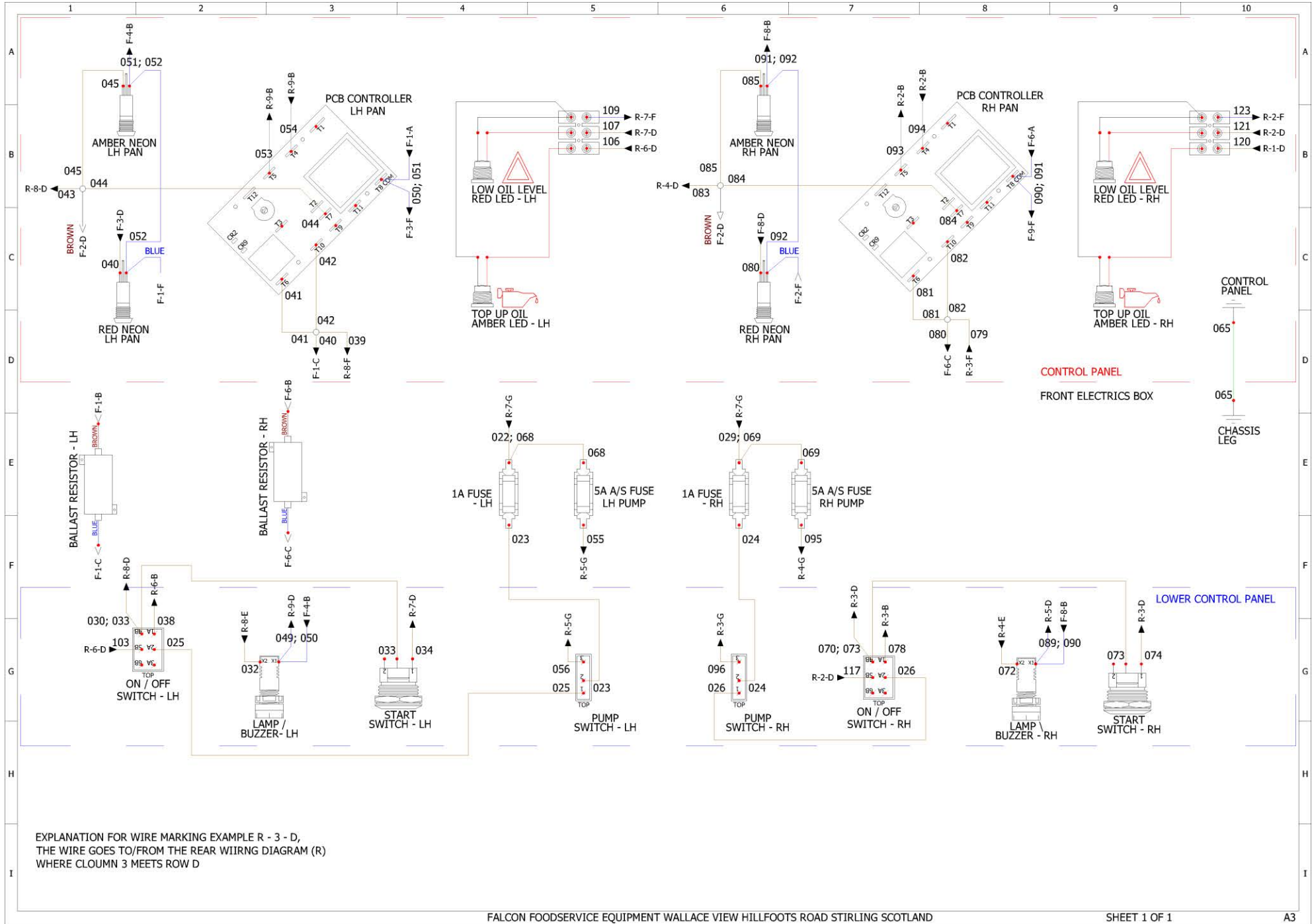

12.17 E3845F2X Rear Wiring Diagram

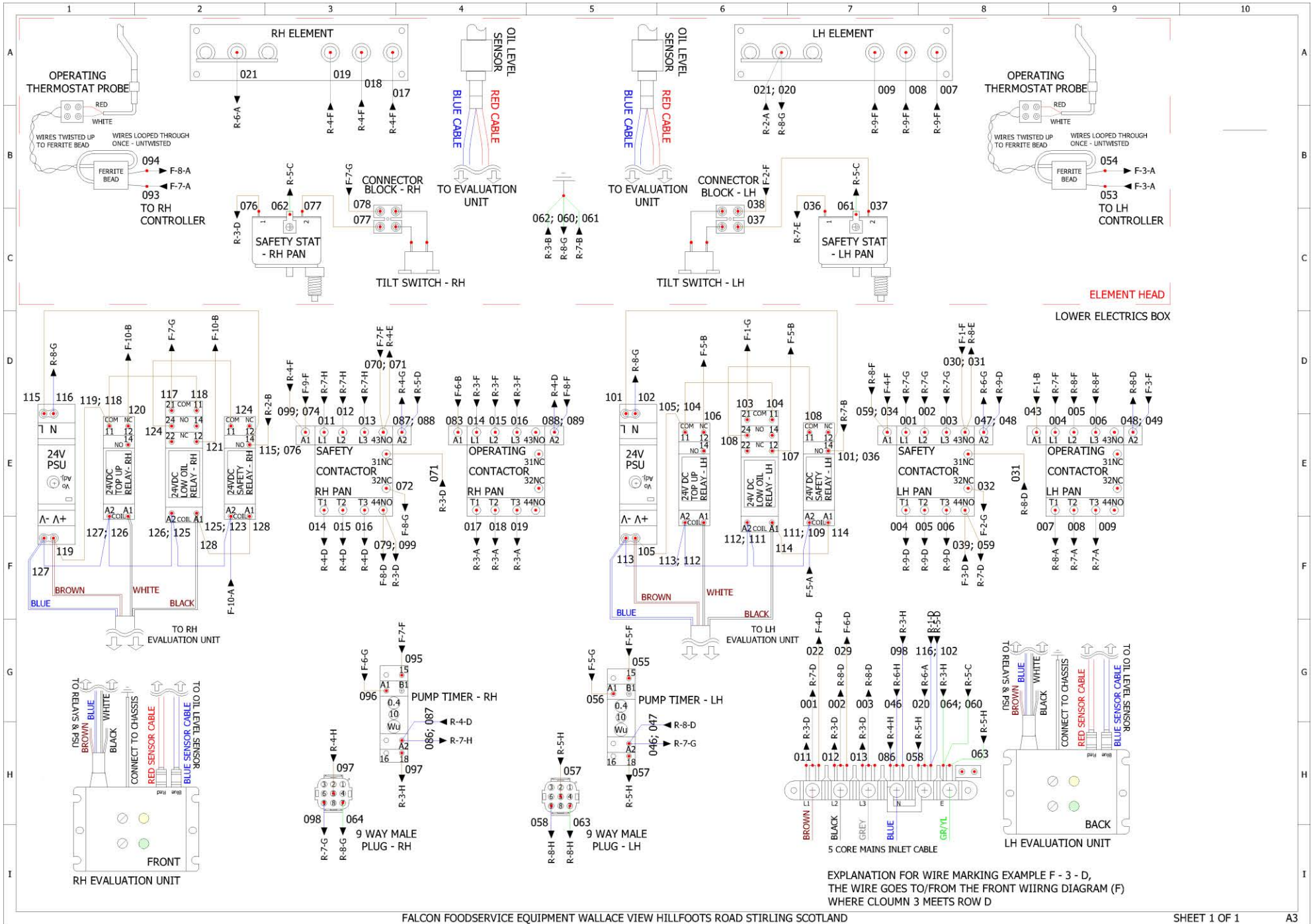

EXPLANATION FOR WIRE MARKING EXAMPLE F - 3 - D,
 THE WIRE GOES TO/FROM THE FRONT WIIRING DIAGRAM (F)
 WHERE COLUMN 3 MEETS ROW D

12.18 E3845F2X Circuit Diagram

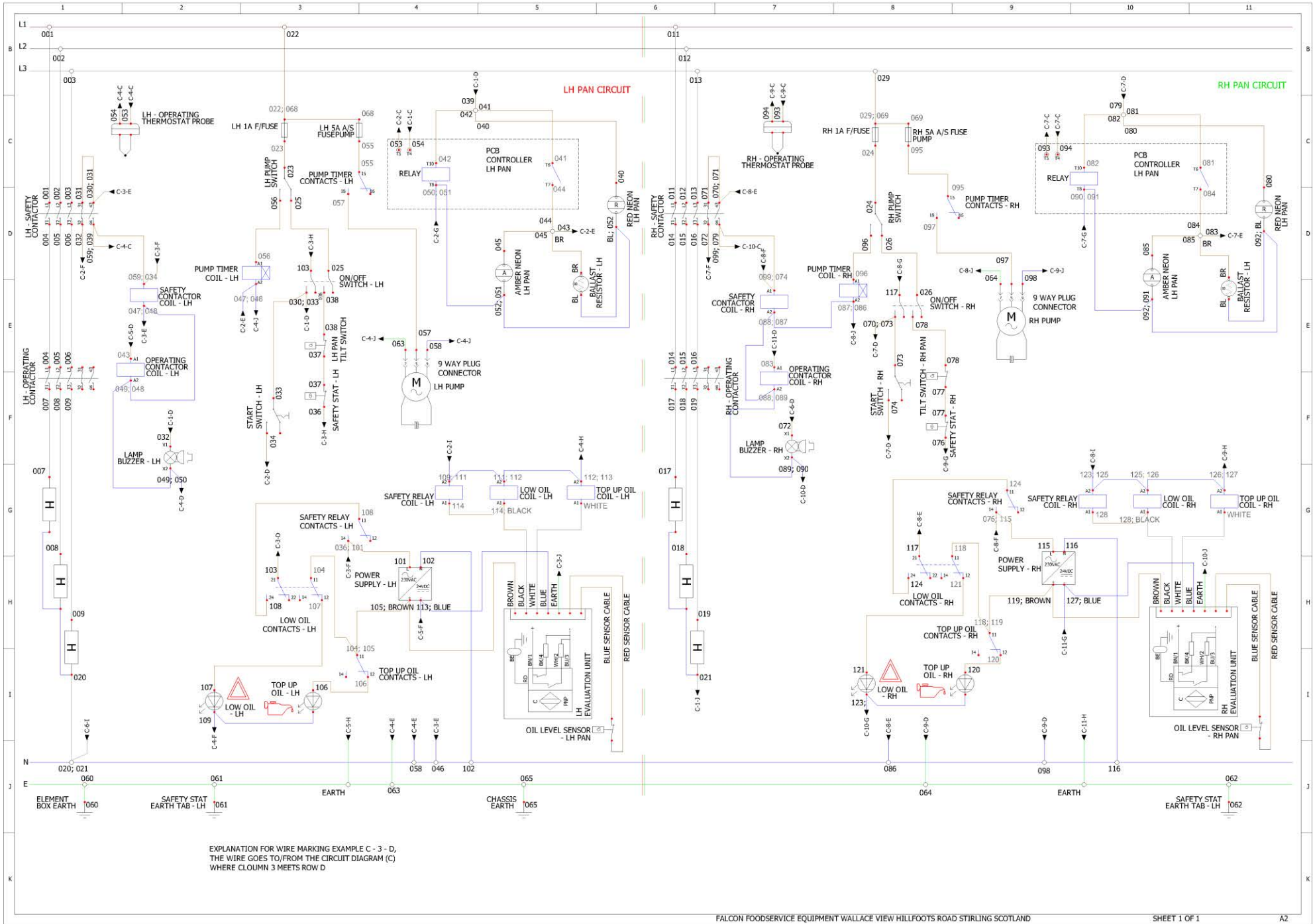

12.19 E3845P Front Wiring Diagram

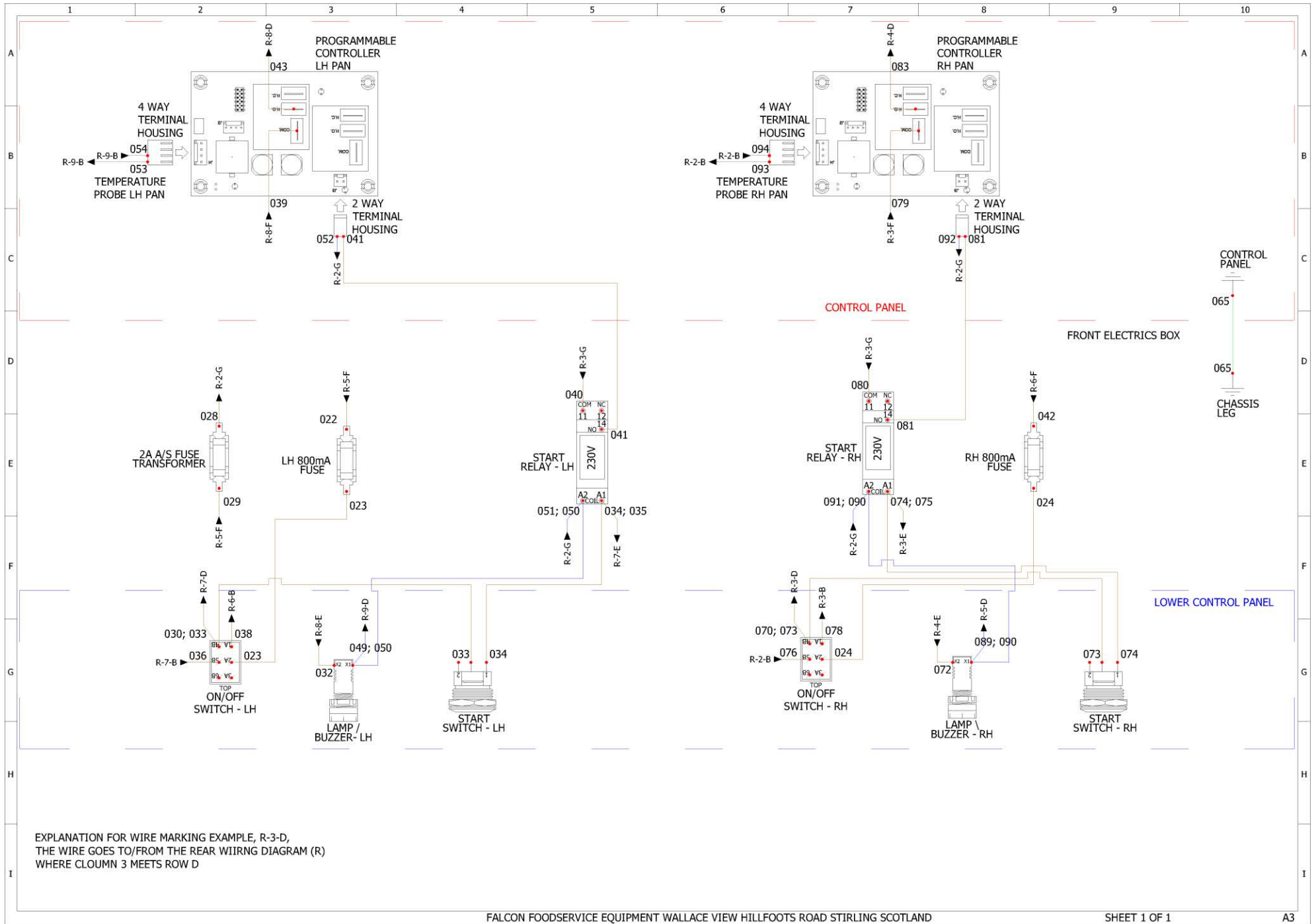

12.21 E3845P Circuit Diagram

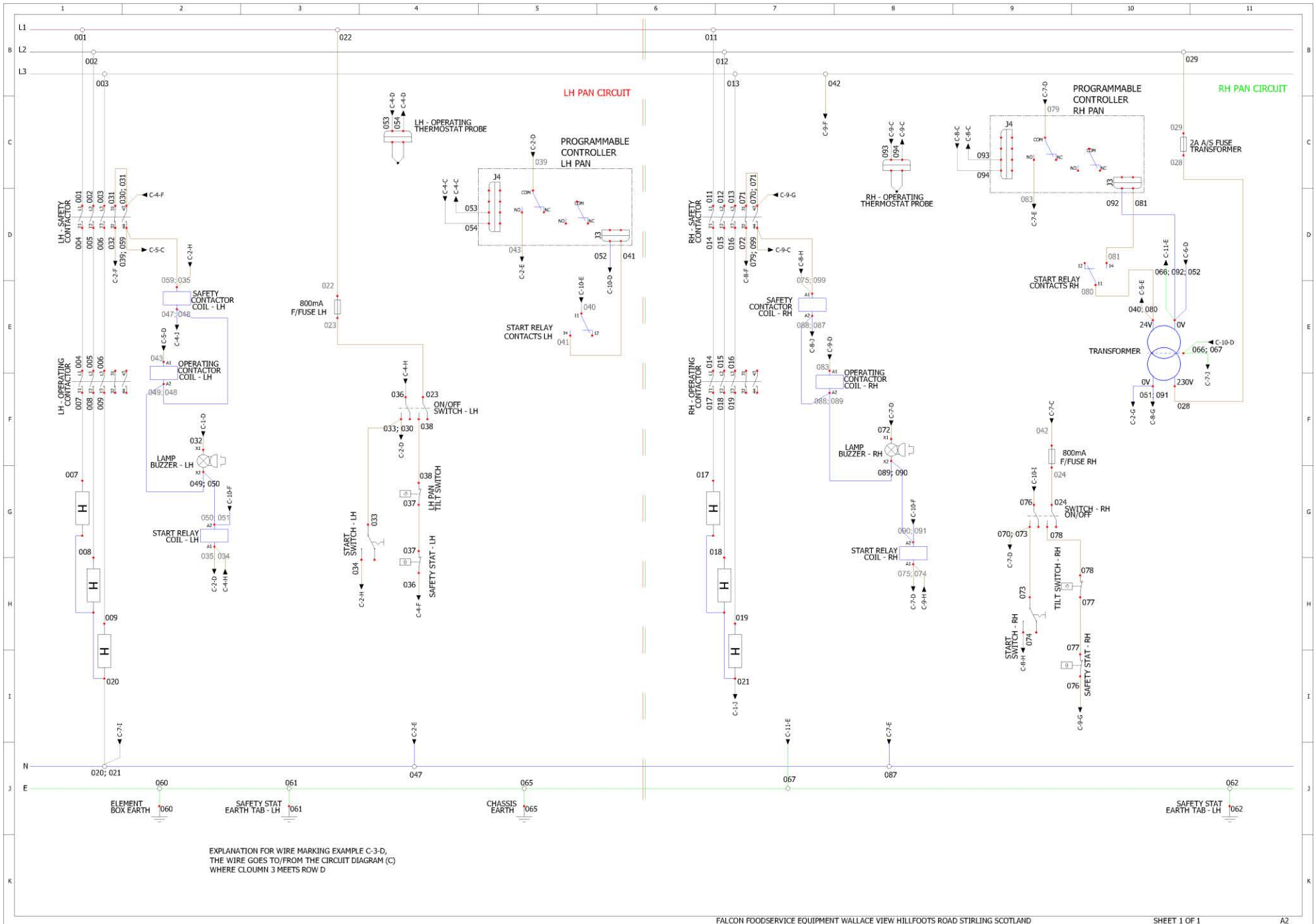

12.22 E3845XP Front Wiring Diagram

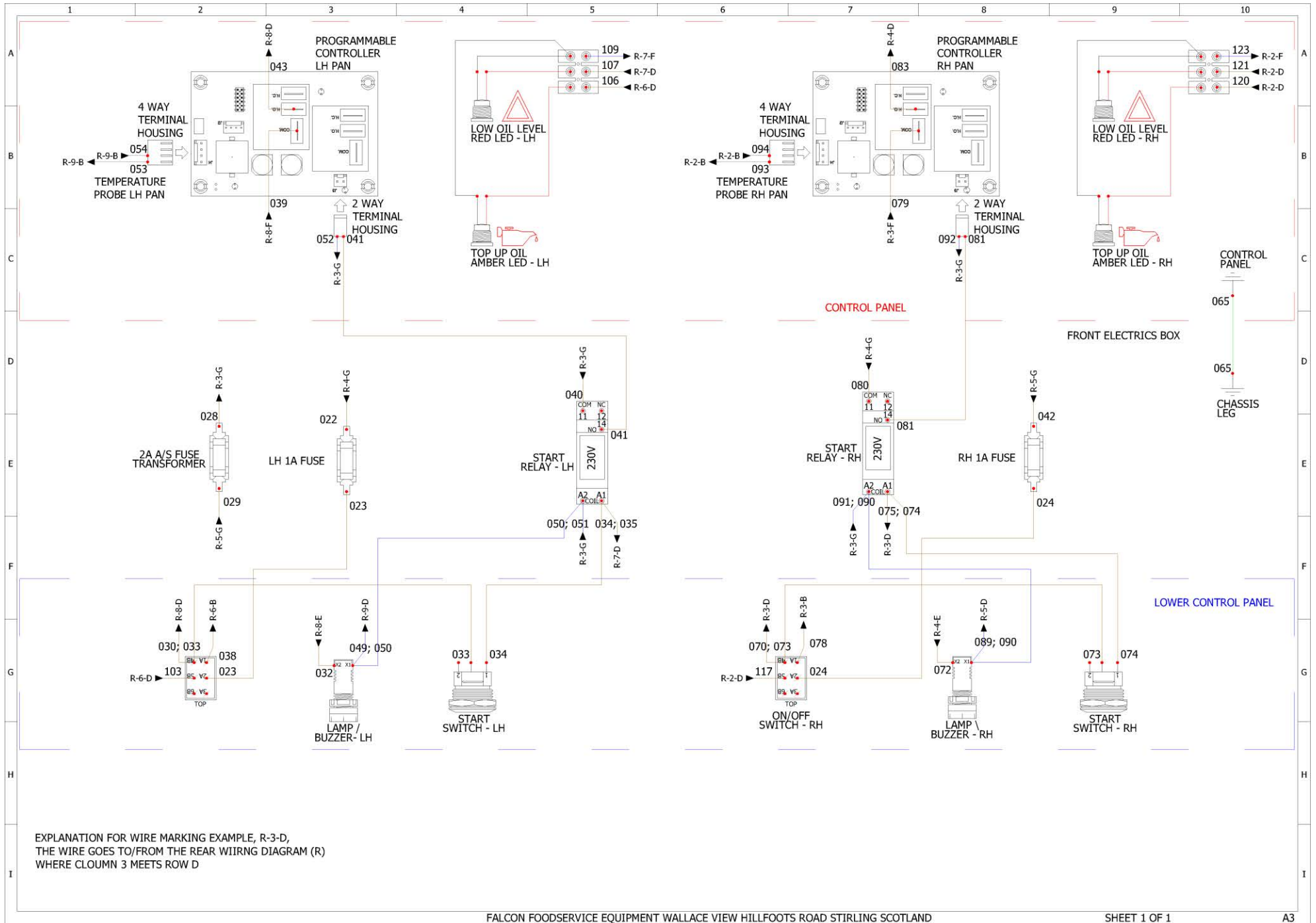

12.23 E3845XP Rear Wiring Diagram

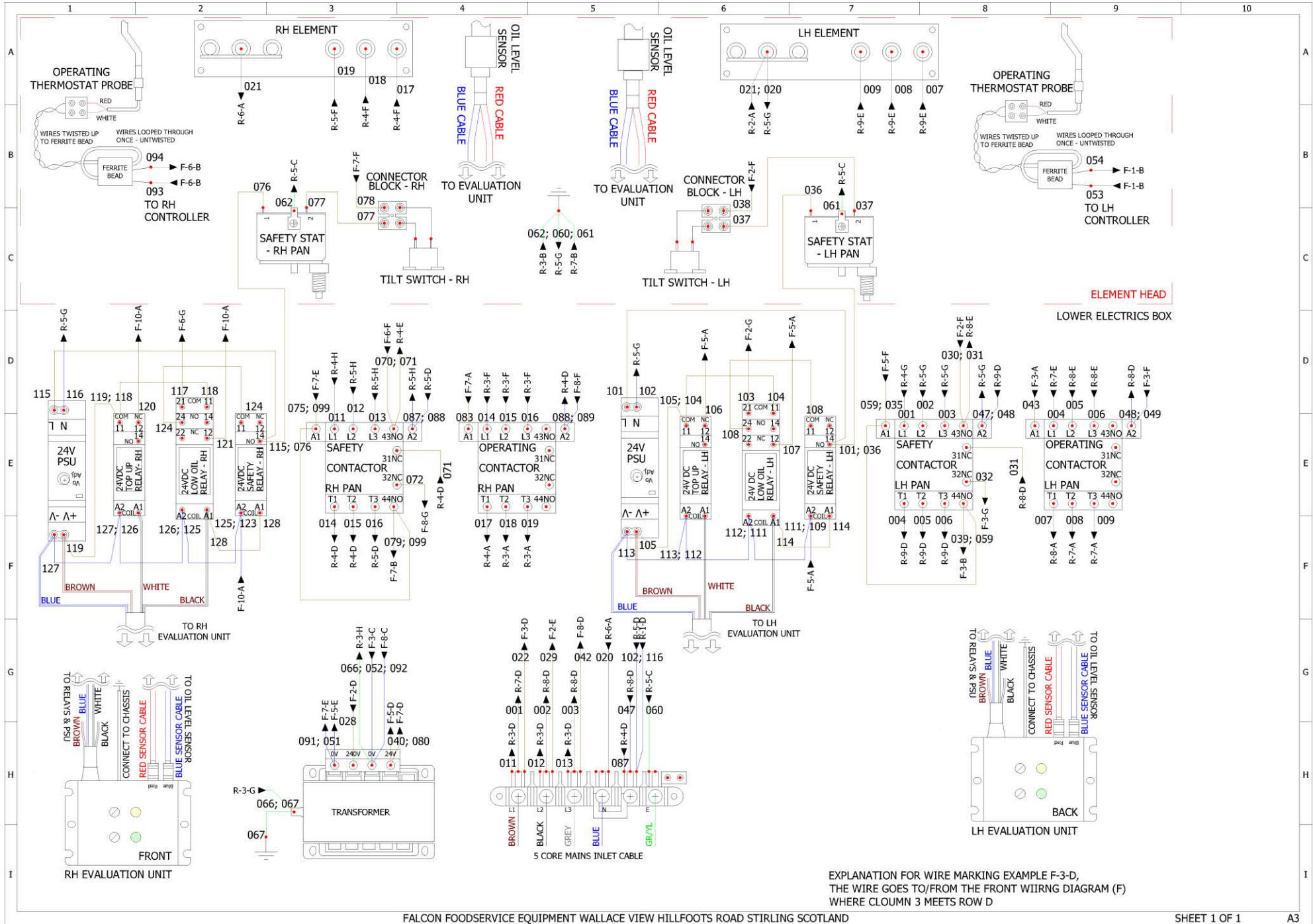

12.24 E3845XP Circuit Diagram

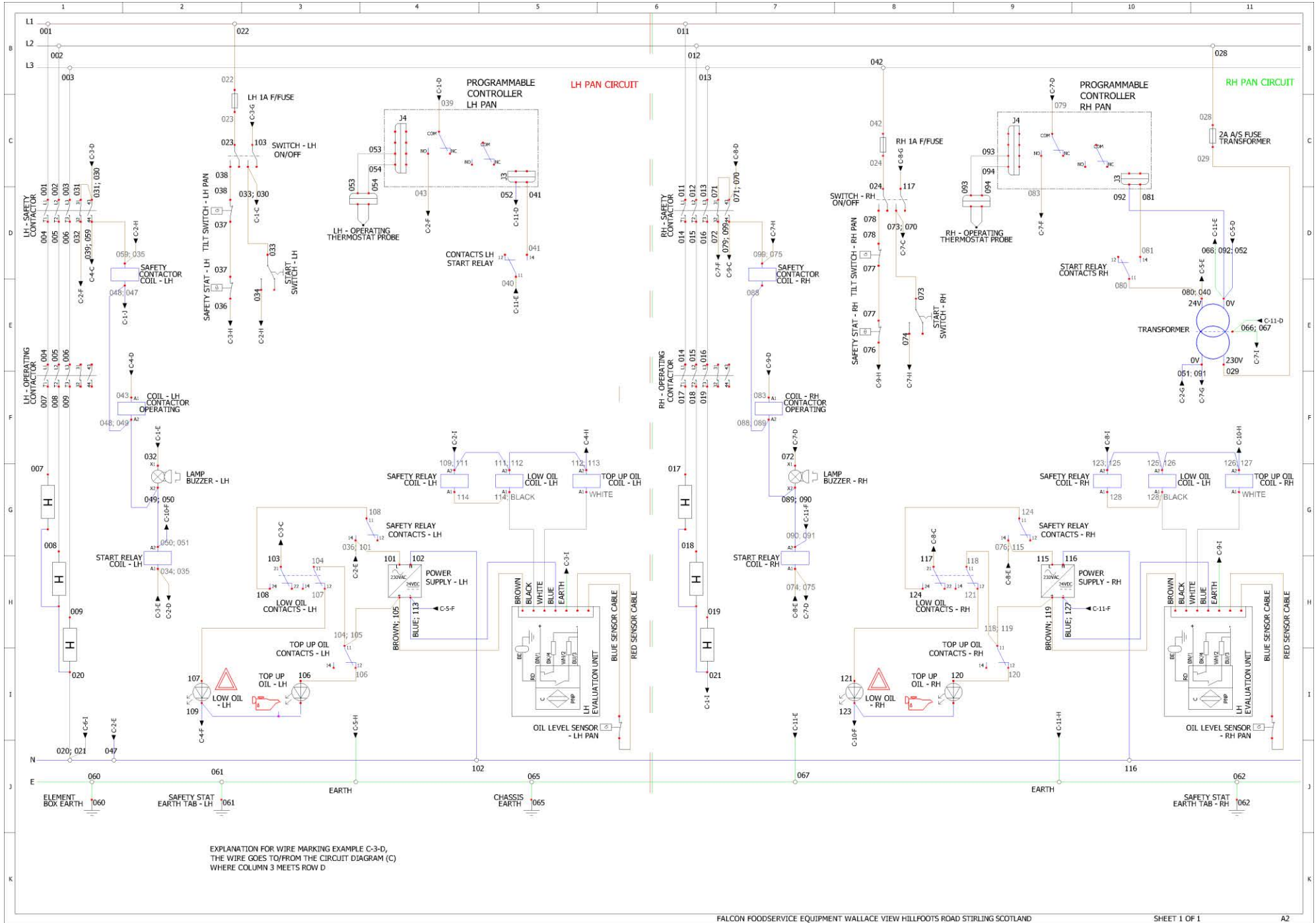

12.25 E3845FP Front Wiring Diagram

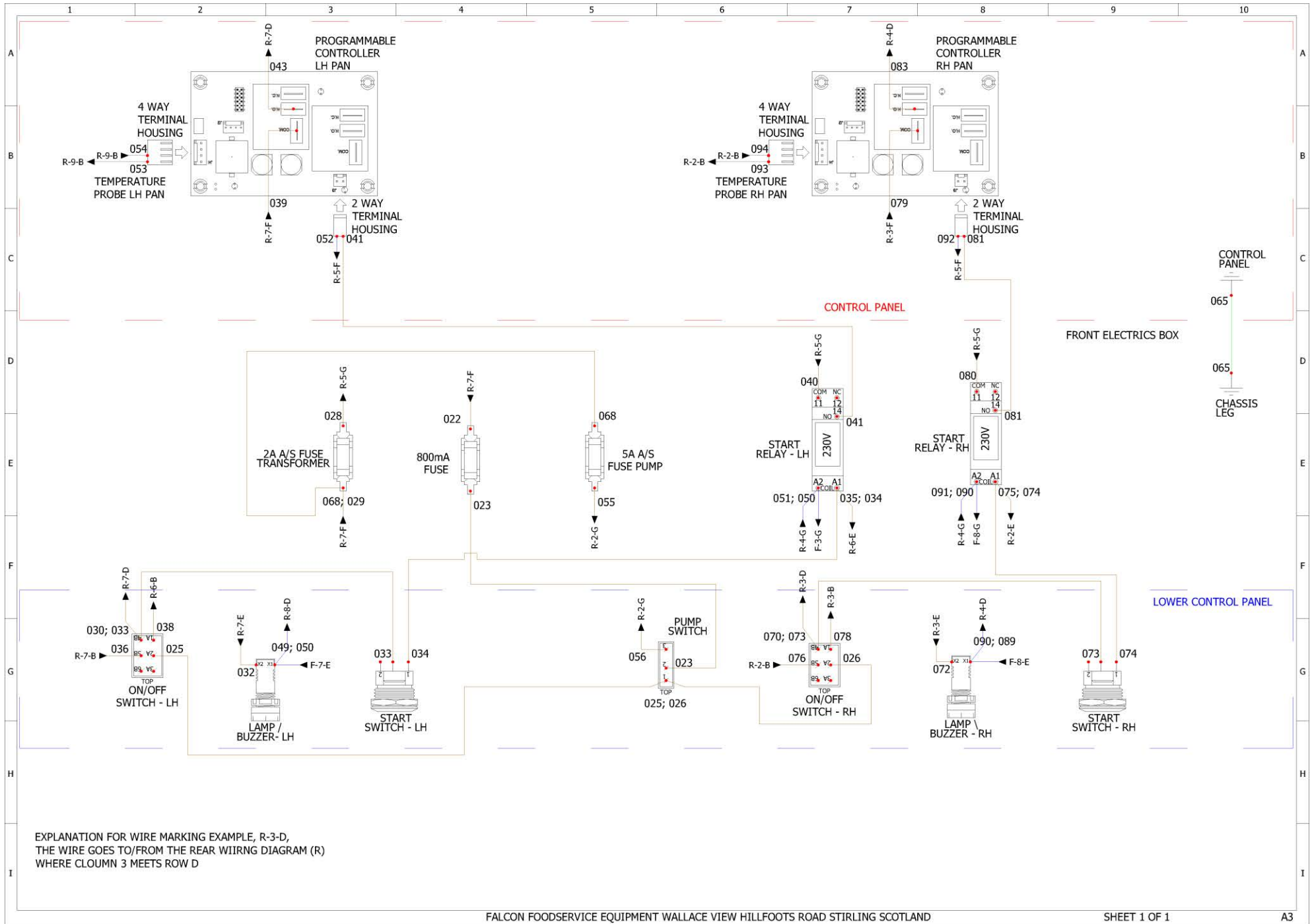

EXPLANATION FOR WIRE MARKING EXAMPLE, R-3-D,
 THE WIRE GOES TO/FROM THE REAR WIIRNG DIAGRAM (R)
 WHERE COLUMN 3 MEETS ROW D

12.26 E3845FP Rear Wiring Diagram

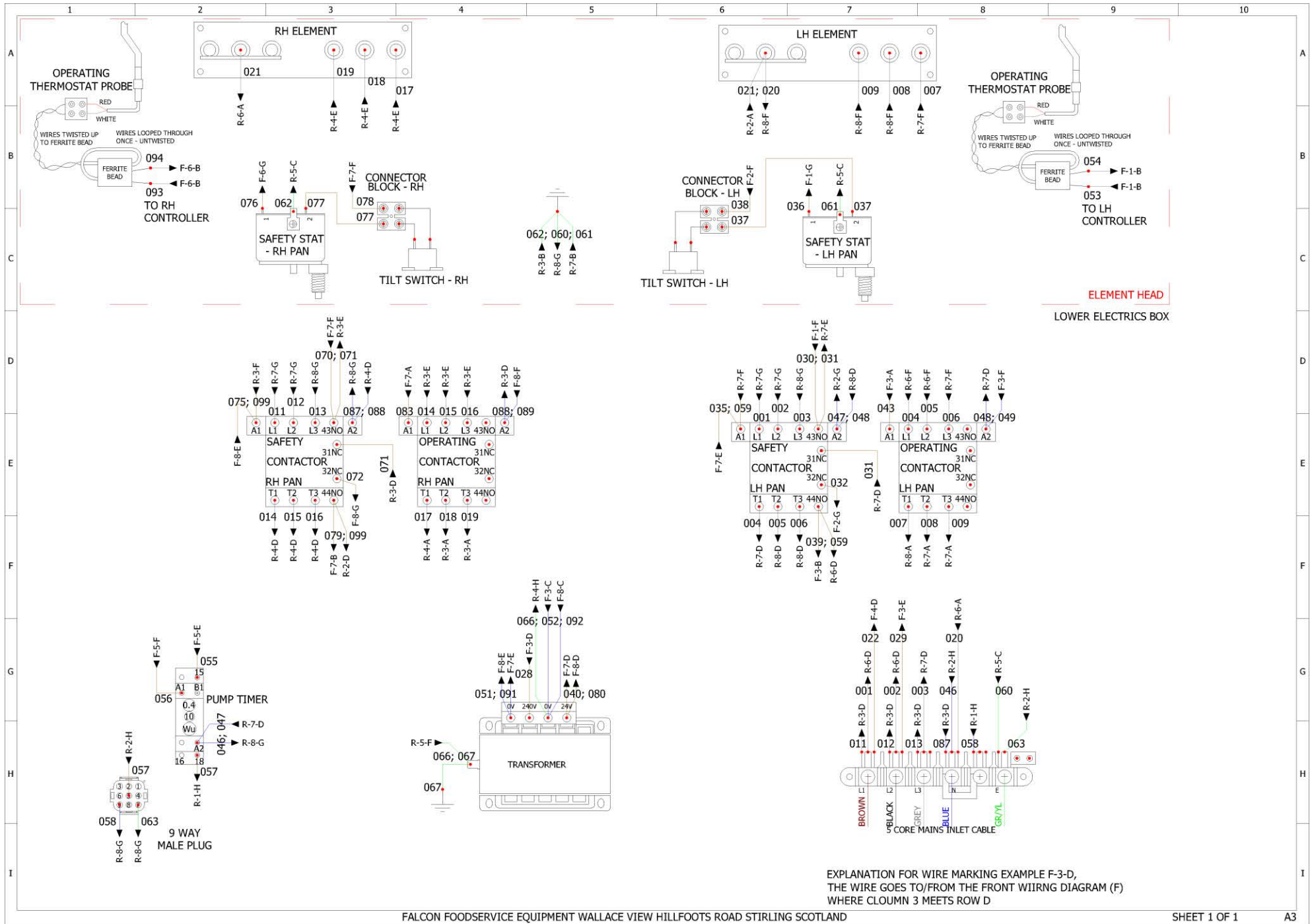

12.27 E3845FP Circuit Diagram

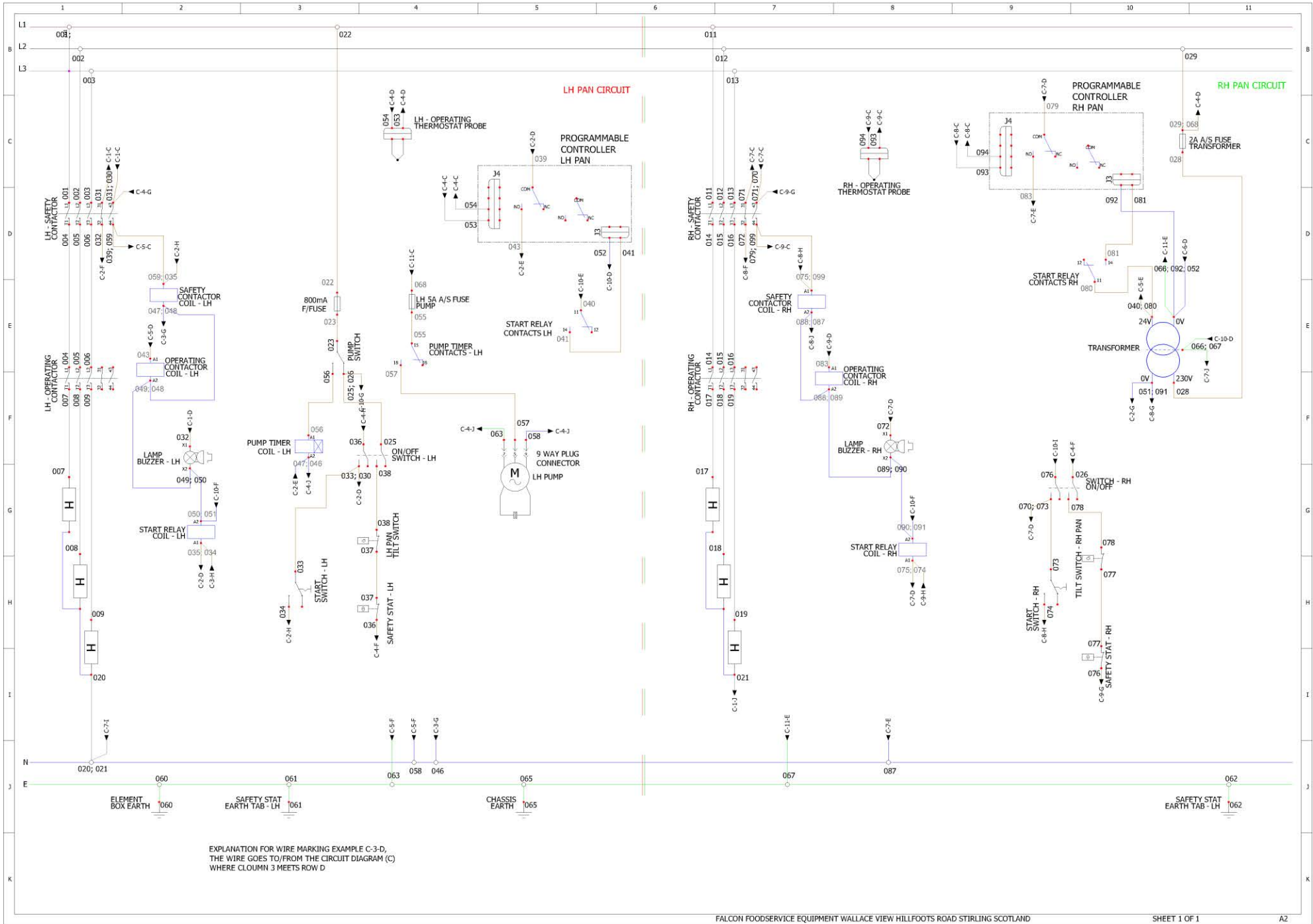

12.28 E3845FXP Front Wiring Diagram

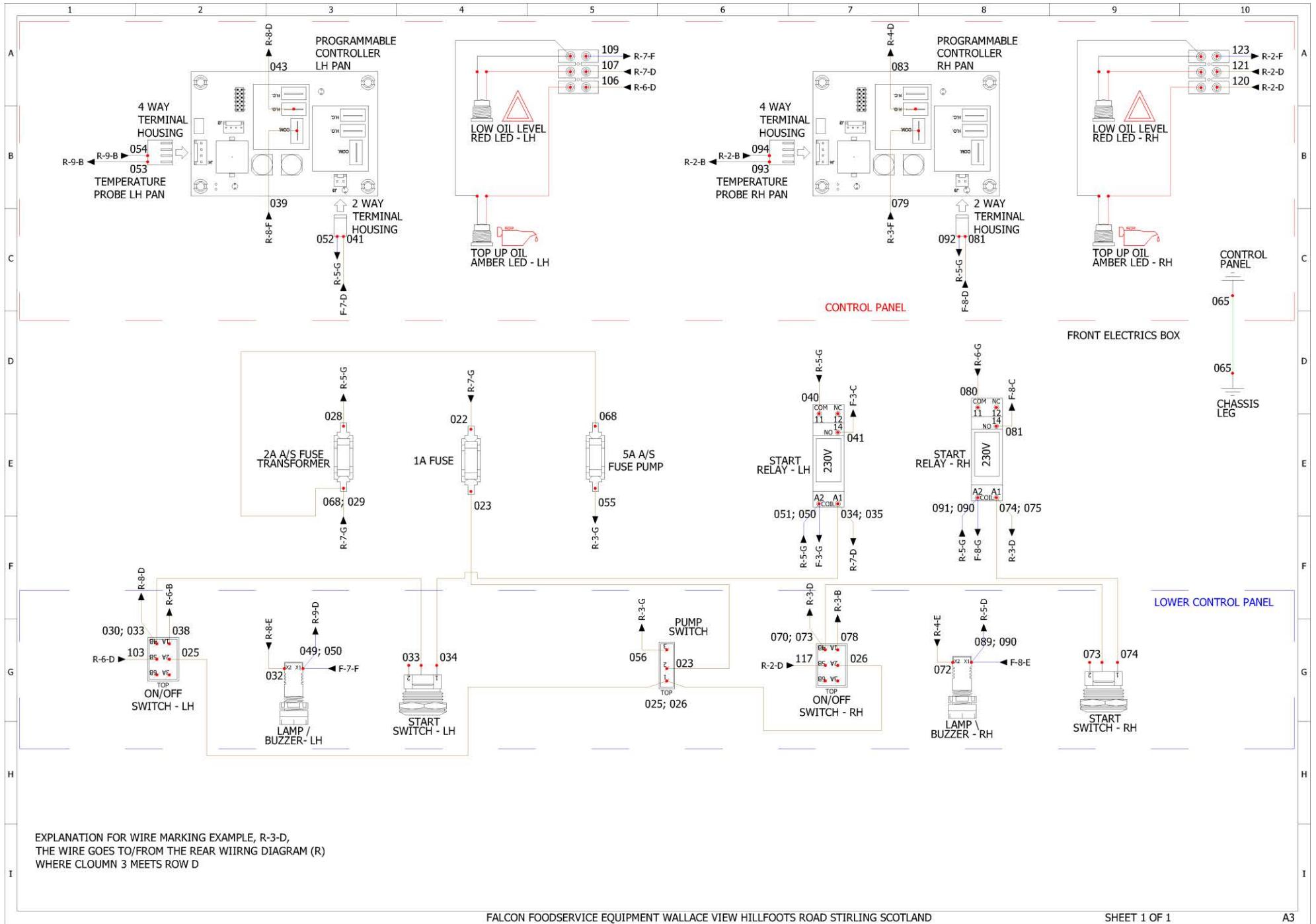

EXPLANATION FOR WIRE MARKING EXAMPLE, R-3-D,
 THE WIRE GOES TO/FROM THE REAR WIIRNG DIAGRAM (R)
 WHERE CLOUWN 3 MEETS ROW D

12.29 E3845FXP Rear Wiring Diagram

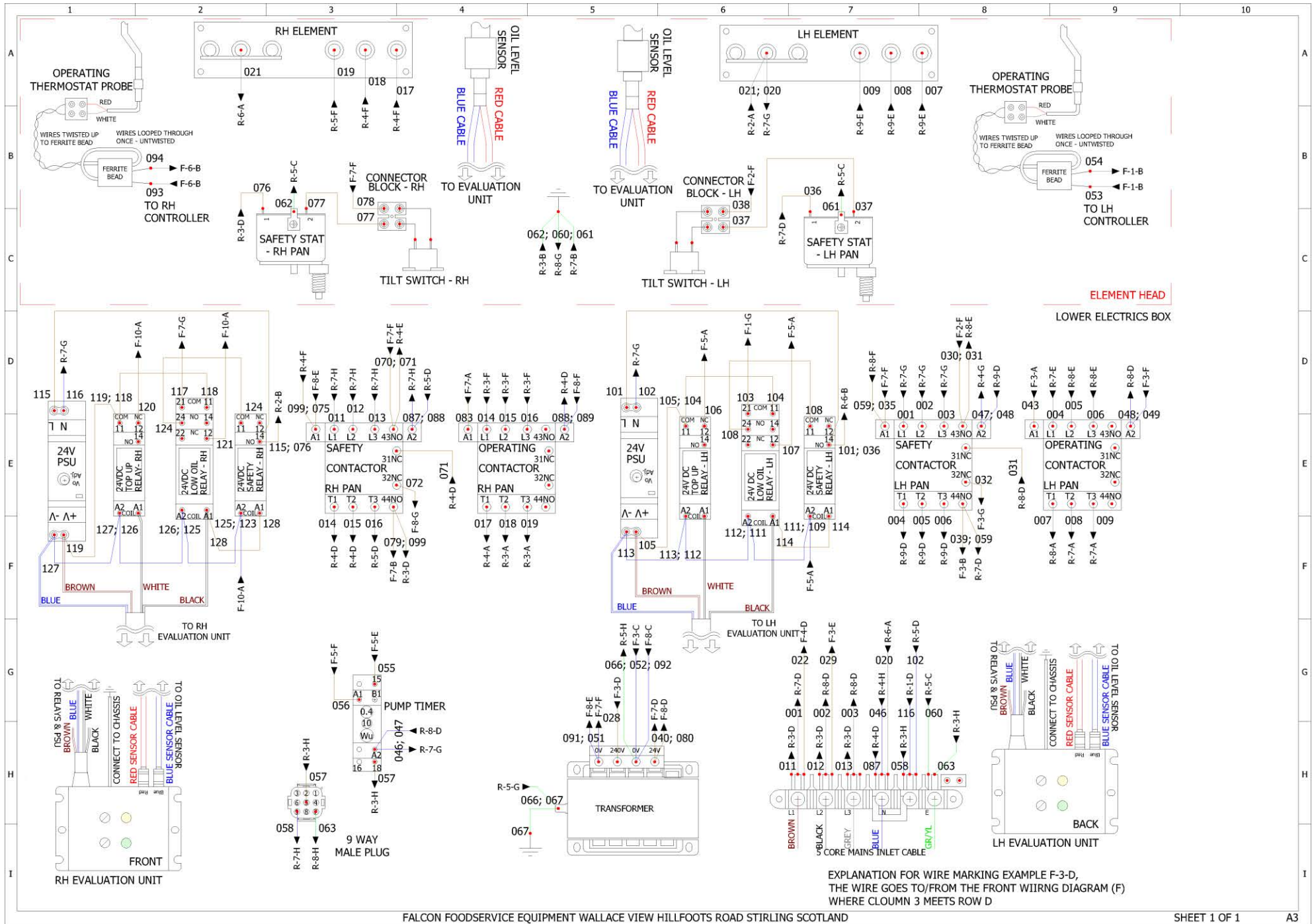

12.30 E3845FXP Circuit Diagram

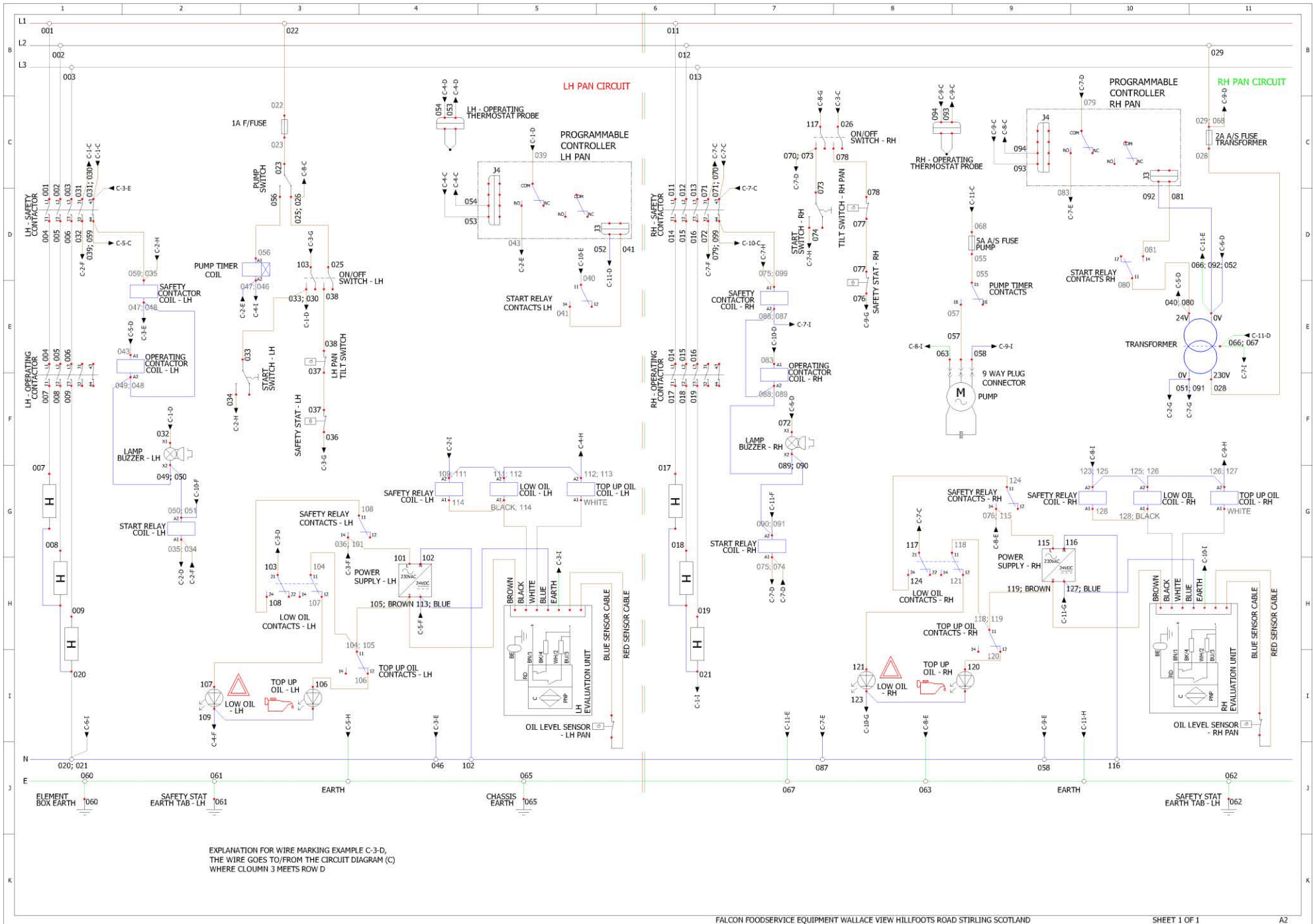

12.31 E3845F2P Front Wiring Diagram

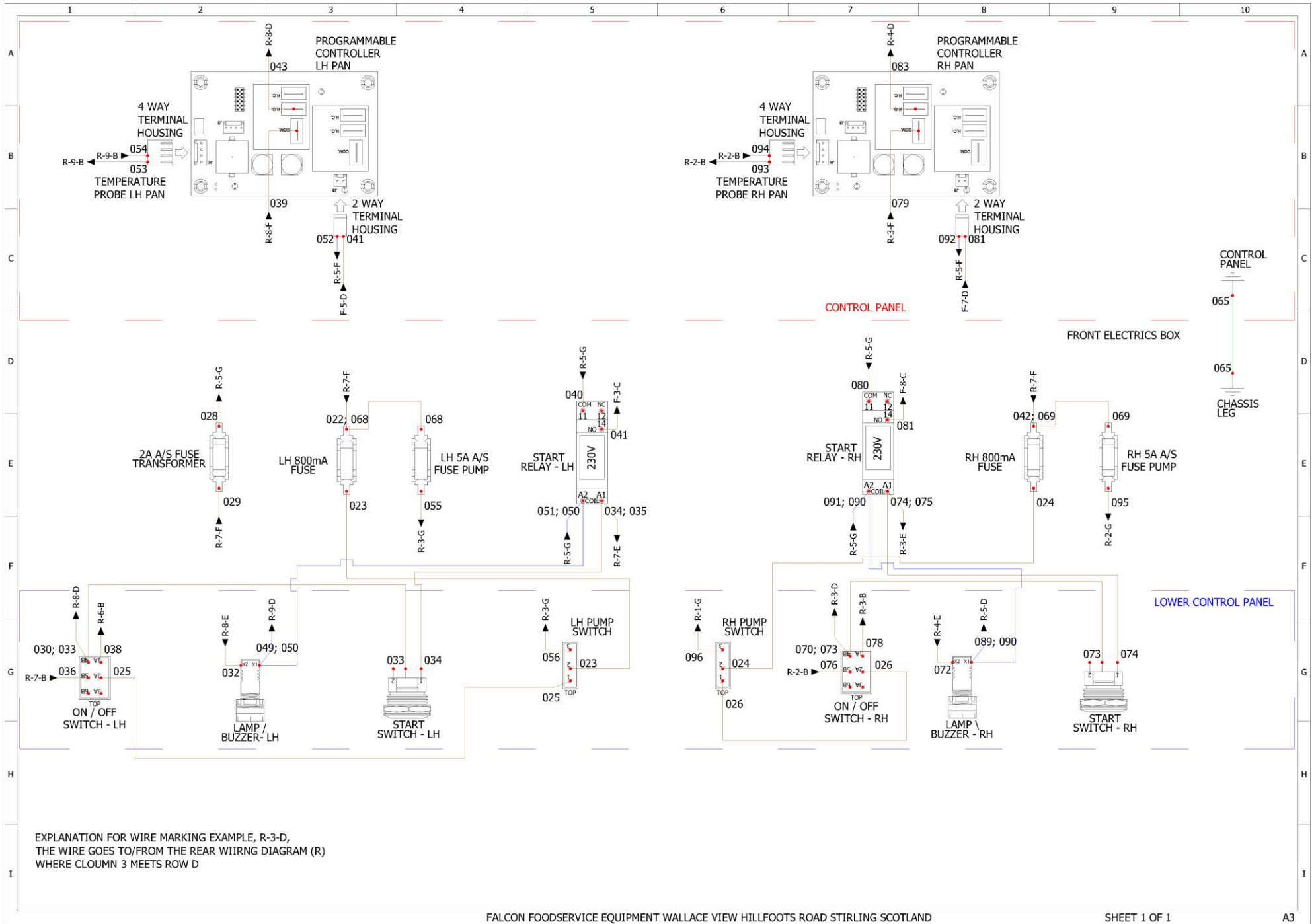

12.33 E3845F2P Circuit Diagram

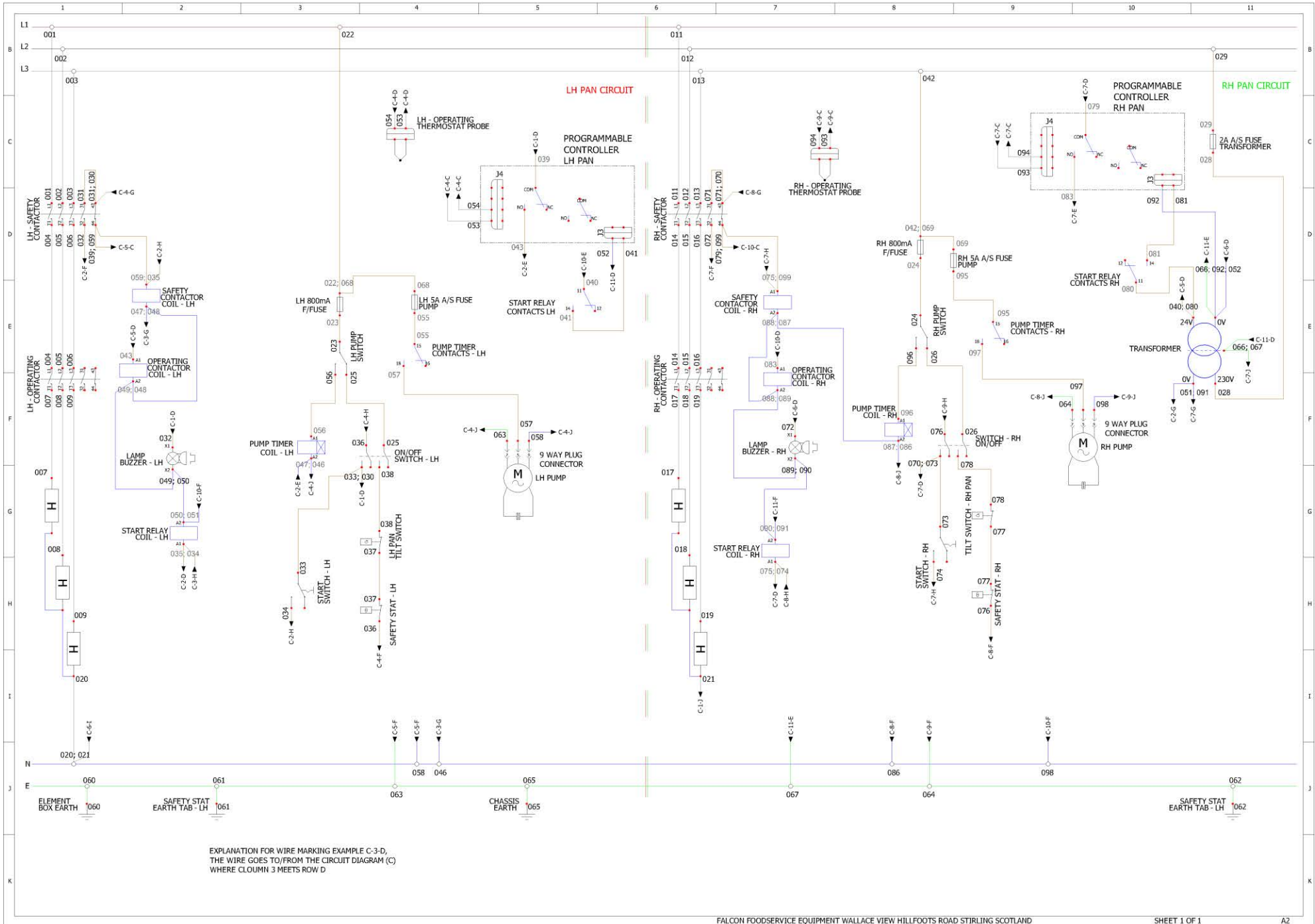

12.34 E3845F2XP Front Wiring Diagram

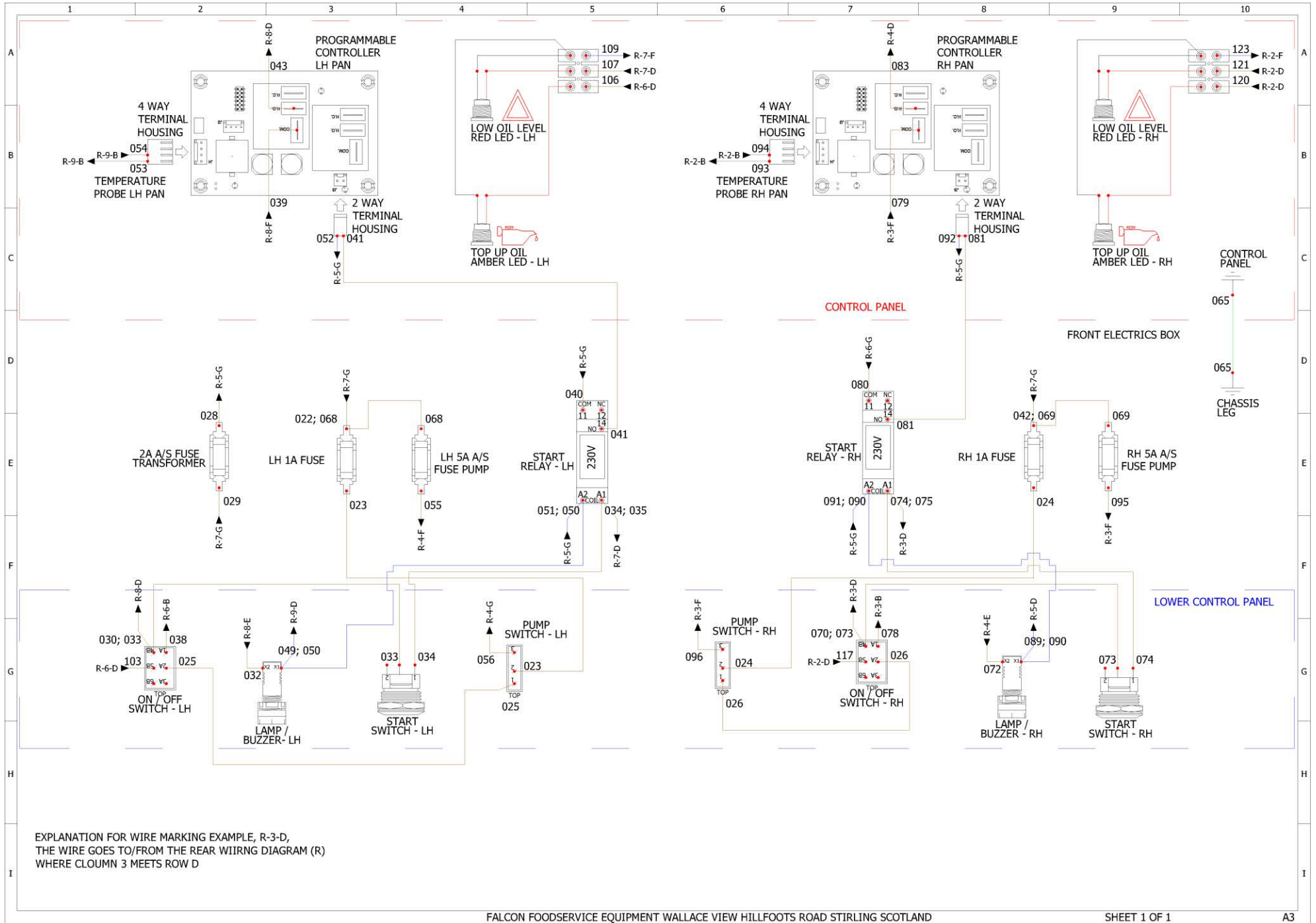

12.35 E3845F2XP Rear Wiring Diagram

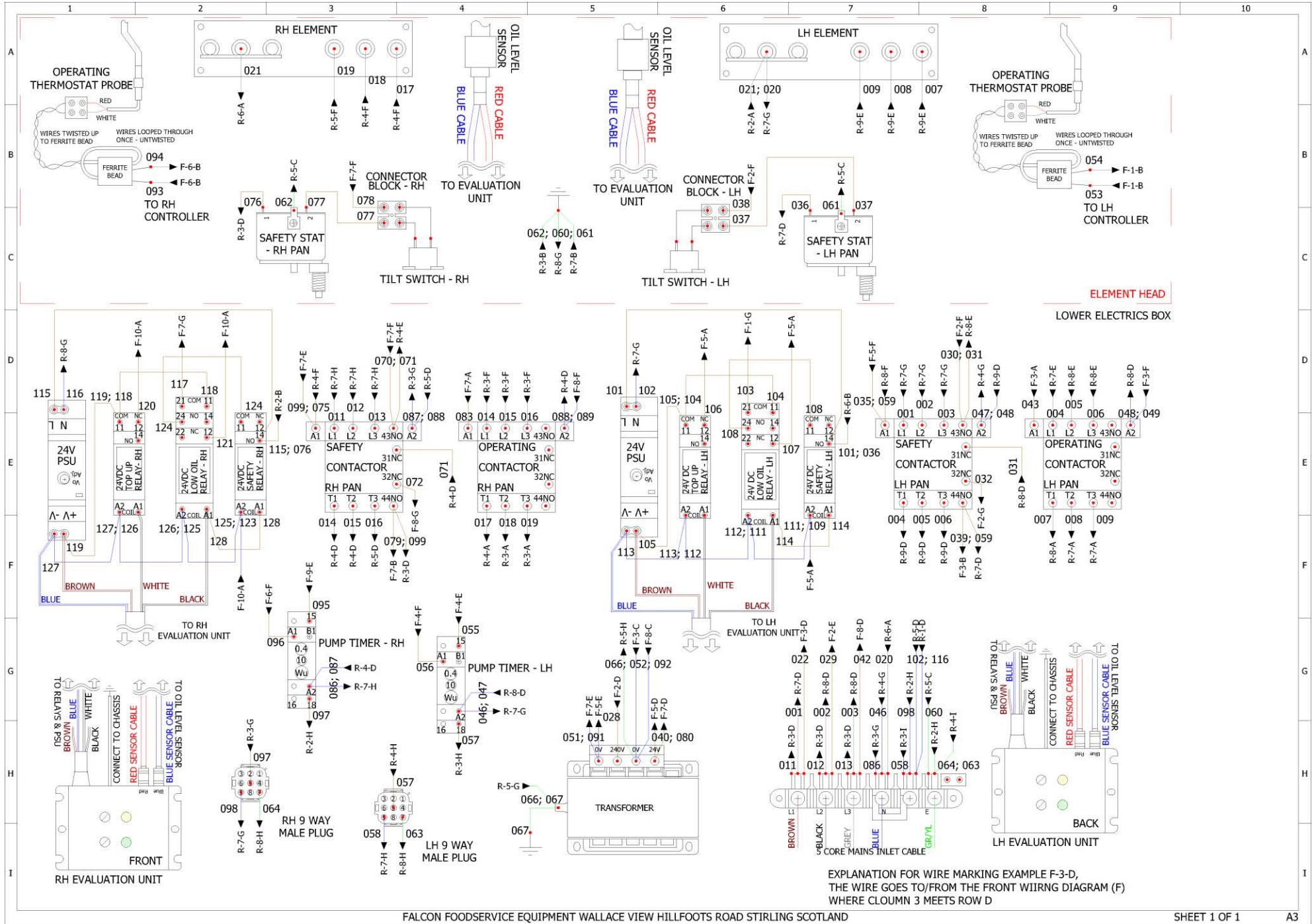

12.36 E3845F2XP Circuit Diagram

